

DRAFT

REQUEST FOR PROPOSALS

FOR

RENEWABLE ENERGY PROJECTS

ISLAND OF OAHU

February 2008



Hawaiian Electric Company, Inc.

Table of Contents

Chapter 1. Introduction and Overview

- 1.1 Purpose of the Request for Proposals (“RFP”)
- 1.2 Objectives of the RFP
- 1.3 Solicitation of Interest and the Grandfathered Proposals
- 1.4 Relationship to the Integrated Resource Plan (“IRP”)
- 1.5 Access to the RFP Website
- 1.6 HECO Contact
- 1.7 Role of the Independent Observer
- 1.8 Dispute Resolution Process
- 1.9 Proposal Submittal Requirements

Chapter 2. Resource Needs and Requirements

- 2.1 Products/Resources Requested
- 2.2 Characteristics of the Resource Required
- 2.3 Performance Standards for Eligible Proposals
- 2.4 Pricing Formula Requirements
- 2.5 Contract Energy
- 2.6 Bid Fees
- 2.7 Contract Size
- 2.8 Power Purchase Agreement (“PPA”) Options

Chapter 3. Instructions to Bidders

- 3.1 Schedule for the Bidding Process
- 3.2 Technical Conference
- 3.3 Submission of Comments on the Draft RFP
- 3.4 Bidders Conference; Notice of Intent to Bid
- 3.5 Preparation of Proposals
- 3.6 Submission of Proposals
- 3.7 Opening of Proposals
- 3.8 Exceptions
- 3.9 Description of the Evaluation Process
- 3.10 Confidentiality
- 3.11 Information on RFP Interconnection
- 3.12 Credit Requirements
- 3.13 Modification or Cancellation of the RFP and Solicitation Process
- 3.14 Organization of the Proposal

Chapter 4. Evaluation Process and Evaluation Criteria

- 4.1 Bid Evaluation and Selection Process
- 4.2 Eligibility Requirements
- 4.3 Threshold Requirements
- 4.4 Initial Evaluation – Price and Non-Price Analysis
- 4.5 Selection of the Initial Short-list
- 4.6 Detailed Evaluation
- 4.7 Selection of the Final Award Group

4.8 Contract Negotiation Process

4.9 Regulatory Approval

Appendix A Notice of Intent to Bid

Appendix B Bidders Response Package

Appendix C Power Purchase Agreement

Appendix D Solicitation of Interest

Appendix E Rule 19 Tariff

Appendix F Background Information on Challenges of Integrating Non-Firm Intermittent Resources

Appendix G Procedures Manual

Chapter 1

Introduction and Overview

1.1 Purpose of the Request for Proposals (“RFP”)

Hawaiian Electric Company, Inc. (“HECO” or the “Company”) seeks proposals for the supply of up to approximately 100 megawatts (“MW”) of long term (i.e. 20 years) renewable energy for the island of Oahu under a Power Purchase Agreement (“PPA”), the terms of which shall be negotiated between HECO and the seller.¹ While this RFP is primarily soliciting proposals for non-firm generation, HECO will also consider proposals for firm energy resources (energy that has the capability of being scheduled or dispatched) as long as the resource qualifies under the Renewable Portfolio Standards (“RPS”) eligibility requirements.

HECO seeks to acquire these resources which would commence commercial operation in the 2010-2014 timeframe, with a preference for resources that achieve commercial operation before 2013. The resources proposed will be evaluated with respect to impacts to the HECO system, adherence to HECO’s performance standards, and their ability to be installed within this preferred timeframe which encourages projects that require no more than modest infrastructure improvements.

This RFP is part of a competitive procurement process established by the Hawaii Public Utilities Commission (the “Commission”).² The process is intended to elicit proposals that will enable HECO to obtain renewable energy generation at a competitive, reasonable cost with reliability, viability and operational characteristics consistent with HECO’s resource planning and energy policy requirements and objectives as set forth in the RFP. This RFP outlines these requirements and provides information and instructions to prospective bidders.

1.2 Objectives of the RFP

The Hawaii Renewable Portfolio Standards (“RPS”) law³ mandates that HECO and its subsidiaries generate or purchase certain amounts of their net electricity sales over time from qualified renewable resources. Those requirements are 10% by 2010, 15% by 2015, and 20% by 2020. Under the RPS Statute, supply-side resources eligible to meet RPS requirements include renewable energy generated or produced by the following sources:

- Wind
- The Sun
- Falling Water
- Biogas, including landfill and sewage-based digester gas

¹ A model PPA for renewable energy resources is attached as Appendix C.

² On December 8, 2006, the Commission issued Decision & Order No. 23121 which contained its Framework for Competitive Bidding.

³ Renewable Portfolio Standard requirements in Hawaii are codified as Hawaii Revised Statutes (HRS) 269-91 through 269-95 (“RPS Law” or “RPS Statute”).

- Geothermal
- Ocean water, currents and waves
- Biomass
- Biofuels
- Hydrogen produced from renewable energy sources

By carefully planning and managing the addition of renewable energy into HECO's system, HECO is implementing a systematic process towards meeting its RPS requirements. HECO believes that having its renewable energy portfolio consist of a diversified mix of resources is the prudent approach to meeting RPS goals. HECO's current consolidated renewable energy portfolio includes wind, geothermal, hydro, biofuel and solar resources, and energy efficiency programs.

By this RFP, HECO intends to procure cost-effective renewable energy resources to help meet RPS requirements and to provide more energy price stability to HECO's customers. HECO will evaluate and select proposals that provide both economic and non-economic benefits to HECO and its customers and adhere to performance standards necessary to protect HECO system reliability. It is expected that any projects that result from this RFP will qualify towards meeting HECO's RPS goals. Renewable Energy Credits or Environmental Credits ("Credits") must accompany any energy purchased by HECO.⁴ In addition, the output from the projects selected and developed through this RFP process may be credited toward the Company's efforts to reduce greenhouse gas emissions. Any resulting PPA(s) will require that all renewable energy credits and greenhouse gas emission credits will be owned by HECO.

The RFP will be open to third-party bidders only. HECO will not submit a self-build option or affiliate bid in response to this RFP.

The successful Bidder(s) will own and operate the facilities proposed and will be responsible for all project costs, including project development, land acquisition, permitting, financing and construction of the facilities.

1.3 Solicitation of Interest and the Grandfathered Proposals

In September 2007, HECO released a Solicitation of Interest (SOI) announcing plans for issuance of this RFP. The SOI is included in this RFP as Appendix D. As noted in the SOI, HECO is continuing discussions with developers of certain proposals for projects that are exempt from the Framework for Competitive Bidding ("Framework") process ("grandfathered proposals"). Those proposals, submitted before adoption of the Framework, involve offers to sell energy or capacity by non-fossil fuel producers and qualify towards meeting HECO's RPS requirements. The grandfathered proposals could result in power purchase agreements for approximately 60 – 135 MW of renewable energy. The grandfathered proposals consist of approximately 30 MW of wind energy located on the north shore of Oahu, 5 MW of energy from synthetic gas derived from waste products, and 25 MW of energy from ocean thermal conversion which could potentially increase to 100 MW. The

⁴ The term "Credits" expressly includes any and all other environmental attributes of any kind that may result from the production of renewable energy purchased, as such attributes are defined by any international, federal, state or local legislation or regulation that is or becomes effective during the term of a renewable power purchase agreement entered into by and between Bidder and HECO.

developer of the 30 MW wind farm grandfathered proposal has also expressed interest in participating in this RFP.

Thus, while this RFP is seeking up to 100 MW of renewable energy, the amount of energy associated with renewable generation capacity that HECO may select through this RFP process could be higher or lower depending on the outcome of negotiations with these grandfathered proposals.

1.4 Relationship to the Integrated Resource Plan (“IRP”)

On October 28, 2005, HECO filed with the Commission its third major IRP Plan (“IRP-3”) in Docket No. 03-0253. On May 31, 2007, HECO filed a 2007 IRP-3 Evaluation Report as an update to HECO’s IRP-3 plan. That Evaluation Report serves as a starting point for HECO’s fourth IRP planning cycle (“IRP-4”). The IRP-3 Evaluation Report plan identified renewable energy for all future supply-side resource needs.

The IRP-3 Evaluation Report plan also identifies the need for 100 MW of renewable energy in the 2010-2012 timeframe. As noted above, some of that renewable energy may be provided as the result of grandfathered proposals.

This RFP is linked to the IRP. The IRP process determines the Company’s incremental resource requirements and the timing of such requirements. This RFP is intended to acquire some of the identified resource requirements.

On October 9, 2007, the Commission issued Order No. 23699 to open a new docket, Docket No. 2007-0331, to receive filings, review approval requests, and resolve disputes, if necessary, related to HECO’s Renewable Energy RFP.

1.5 Access to the RFP Website

HECO intends that the primary means of contact with prospective bidders and other interested parties will be via the Company’s RFP website. The website link is generationbidding.heco.com. The HECO Generation Bidding website will be the primary means of communication between the Bidders and HECO. Links will be available for submitting questions to HECO and any updates to the RFP will be posted. The website will have two levels of information. The first level will contain all publicly available information such as the RFP and any associated updates, and questions and answers submitted throughout the RFP process. A second level will be made available only to Bidders, and if appropriate, parties that submit an acceptable Notice of Intent to Bid prior to bid submittal. Access to this level will be controlled by a registration process and secured password. Information provided at this secure level will principally contain information exchanged between HECO and Bidders for the purposes of clarifying Bidder’s proposals after bids have been submitted. This level may also include information and documents that contain confidential and/or proprietary information.

1.6 HECO Contact

Proposals should be submitted to HECO's Project Manager for this RFP at the address below:

Colette Miller
Generation Bidding Project Manager, MS-WA3/XB
HECO
P.O. Box 2750
Honolulu, Hawaii 96840
genbid@heco.com

1.7 Role of the Independent Observer

The Commission's Decision and Order (No. 23121) in Docket No. 03-0372 (Instituting a Proceeding to Investigate Competitive Bidding for New Generating Capacity in Hawaii) states that an Independent Observer ("IO") is required whenever HECO or an affiliate seeks to advance a project proposal (in competition with those offered by bidders) in response to a Company RFP for generation capacity (or otherwise as determined by the Commission). Although neither HECO nor any affiliate will advance a project proposal, HECO nevertheless has retained an IO to oversee and monitor the bidding process⁵. The IO will coordinate with Commission staff throughout the bidding process to ensure the process is undertaken in a fair and unbiased manner.

The role of the IO will include the following:

1. Monitor all steps in the competitive bidding process.
2. Monitor communications (and communications protocols) with bidders.
3. Monitor adherence to the utility's Code of Conduct.
4. Submit comments and recommendations, if any, to the Commission concerning the RFP
5. Review the utility's bid evaluation methodology, models, criteria, and assumptions.
6. Review the utility's evaluation of bids.
7. Advise the utility on its decision-making
8. Monitor contract negotiations with bidders
9. Report to the Commission on monitoring results during each stage of the competitive bidding process
10. Provide an overall assessment of whether the goals of the RFP were achieved

The IO for this RFP is listed below:

New Energy Opportunities, Inc.
10 Speen Street
Framingham, MA 01701

Attention: Barry Sheingold, President
Phone: (508) 665-5888

⁵ HECO's decision to retain an Independent Observer for this RFP has been approved by the Commission. Order No. 23699 (Docket No. 2007-0331 (Oct. 9, 2007) at 13-15.

Fax: (508) 665-5858
bjs@newenergyopps.com

1.8 Dispute Resolution Process

If disputes arise under the competitive bidding process, the dispute resolution process established in the Framework will control.

As ordered in Docket No. 2007-0331, the Commission will serve as the arbiter of last resort for any disputes relating to this RFP. Bidders who are challenging or contesting any aspects of the RFP process must first attempt to resolve their concerns with the Company and the IO. The IO will seek to work cooperatively with the parties to resolve any disputes or pending issues or to mediate between the parties to resolve disputes prior to such issues coming before the Commission. Should the Company and the IO be unable to resolve a Bidder's concerns, the Bidder may then seek determination of the issue by the Commission. The Commission will use an informal expedited dispute resolution process to resolve the issue within 30 days, as described in Parts III.B.8 and V of the Framework⁶. There shall be no right to hearing or appeal from this informal expedited dispute resolution process.

1.9 Proposal Submittal Requirements

Proposals must be received by HECO's Generation Bidding Project Manager by 4:00 pm on the date shown in the schedule in Chapter 3 of this RFP. All proposals must be prepared in accordance with the procedures specified in the RFP. This process is intended to provide an orderly, consistent and fair evaluation process. Bidders are required to respond to all questions and provide information requested in both Chapter 4 and in the Response Package of this RFP. Items which are not applicable to a specific Bidder or project type must be clearly marked N/A and a brief explanation must accompany each item so marked. All proposals must follow the specified format. It is the Bidder's responsibility to advise the Company's Official Contact of conflicting requirements, omission of information, or the need for clarification before Proposals are due. All proposals must remain valid through the award period. A Bid Deposit Security of \$3/kW based on the nominal capacity of the proposal will be required for all Bidders selected for the short list.

⁶ The informal expedited dispute resolution process does not apply to Commission review of contracts that result from the RFP. Decision and Order No. 23121 at 34-35. Nor does it apply to the Framework's process relating to issuance of a draft and final RFP and Commission approval of the RFP since (a) the Framework (and this RFP) set forth specific processes whereby interested parties may provide input through the submission of comments and (b) the Framework's dispute resolution process applies to "bidders" and there are no "bidders" as of yet at this stage in the RFP process.

Chapter 2

Resource Needs and Requirements

2.1 Products/Resources Requested

HECO will accept proposals from all eligible suppliers of renewable resources that are able to meet the RPS requirements in Hawaii. Generation must be provided from either new facilities or from demonstrated expansion of existing eligible facilities. Since it is not a requirement that bidders provide firm capacity and qualifying bids providing firm capacity are not anticipated, firm capacity payments are not being offered in this RFP.

The key parameters for the proposals requested through this RFP and the requirements for the proposal are identified in Chart 1 below.

Chart 1

Summary of Bidding Requirements

Product Parameters	Requirements
Type of Product	HECO is primarily interested in proposals for non-firm renewable energy or intermittent resources. HECO will consider proposals for firm energy resources (limited dispatchable/schedulable generation).
Size of contract	Up to 100 MW
Contract Term	Bidders are allowed to propose a term of 20 years commencing from project commercial operation
Minimum Output	The base proposal should have an aggregate net output exceeding 5.0 MW. The Framework does not apply to projects proposed for the HECO system that are 5 MW or less. Such projects may be submitted directly to HECO for consideration and do not have to participate in a competitive bidding process.
Commercial Operation Date	Bids must be for projects with commercial operation dates between 2010-2014. However, HECO prefers proposals that can reasonably demonstrate they can achieve commercial operation prior to 2013.
Eligible Resources	Generation resources that will produce renewable energy qualifying under the RPS Statute are the only resources eligible to

	bid in this RFP.
Contract Types	HECO will be offering a PPA for energy only. No firm capacity payments will be offered for this RFP.

2.2 Characteristics of the Resource Required

The experience of HECO and its affiliates with integrating intermittent renewable resources (e.g., wind) onto a small isolated island grid is that such resources present challenges in operating the system and maintaining system stability. In addition, HECO is interested in ensuring that additional renewable resources can be added to the system in the future at reasonable integration costs. Some of the challenges that will affect the desired performance standards and characteristics of the projects are expected to include:

- System stability – ensuring that the HECO system will not experience blackout following line faults and generation loss with high intermittent or dispatch limited resource penetration.
- Optimizing unit scheduling – requires accurate hour-ahead and day-ahead forecasts, not readily available from intermittent resources.
- Frequency control – variations in the output of intermittent resources can cause variations in system frequency. If frequency deviations become too large, the system is less stable and can lead to short customer outages (under frequency load shed) or extensive outages (if the deviation leads to system failure).
- Voltage control – variations in the output of intermittent resources may cause variations in system voltage. Low voltage may result in customer equipment being damaged. If voltage deviations become too large, the system is less stable and can lead to short customer outages (under voltage load shed) or extensive outages (if the deviation leads to system failure).
- System management – standard Energy Management Systems (EMS) are not configured to work with high wind penetration. They must be “tuned” to account for the variable output of wind farms and direct the rest of the system to respond to those fluctuations. If the EMS is not tuned properly it could worsen the fluctuations.
- Cost and emissions related to providing additional regulating reserve – providing the regulating reserve to account for the irregular nature of intermittent resources can require the commitment of additional regulating units and require the regulating units to operate at reduced fuel efficiency which increases both costs and emissions for those units. Constant regulation to counter the intermittent variations also increases the wear and tear on the regulating units.

In addition to the general issues related to high levels of intermittent resource penetration, Hawaii faces a unique set of challenges to integrating such resources onto its grids. These include having no interconnections to other grids for support, little geographic diversity, and a unique mix of generation resources. HECO is currently researching how other utilities with relatively small isolated systems and a comparable generation resource mix are striving to deal with the operational challenges

associated with increased penetration of intermittent resources. These challenges include the maintenance of stable frequency and voltages. While the HECO utilities (HELCO and MECO) are presently among the leaders internationally in terms of the large penetration of wind energy already integrated on its grids, an available source of useful data from other systems is fairly limited, particularly from other small isolated electrical systems that are most directly comparable.

Nevertheless, work continues on the analyses that have been identified in the IRP filings for HECO, HELCO, and MECO to evaluate the impact of intermittent renewable energy resources (such as wind farms) on the Companies' systems, and renewable energy infrastructure projects identified as part of the Companies' proposed Renewable Energy Infrastructure Program in the RPS Framework Docket No. 2007-0008 that are intended to assist in the integration of more non-firm and other non-dispatchable renewable projects onto the electrical grid than could otherwise be added without such projects.⁷ To effectively maximize the amount of renewable resources that can be integrated into the Oahu system, HECO must address the challenges that non-firm resources present and facilitate its integration in a manner that balances the need to maintain reliable operation and customer expectations for power quality. For the benefit of Bidders in this RFP, HECO has included background information previously provided to members of HECO's IRP Advisory Group on the challenges of integrating non-firm energy on our system in Appendix F.

These integration challenges can be addressed by various approaches. One such approach would be to have all renewable energy providers incorporate design features into their projects that can address all of the system integration requirements identified by the utility. Such features could include adherence to strict performance standards, installation of equipment and technology to mitigate fluctuations such as power conditioning equipment, installation of energy storage devices, self-curtailment of output, and enhanced forecasting ability.

The contrasting approach would be for the utility to incorporate grid side mitigation measures such as operating with higher levels of regulating reserve, operating its units in non-economic dispatch modes, installing energy storage devices, and installing more quick start and fast response generation.

The optimal solution to this integration challenge is anticipated to involve some level of cooperation and contribution from both the suppliers and the utility, in arriving at a combination of technical solutions and operating procedures that maintain system reliability at a reasonable cost to customers. It is this cooperative approach that HECO proposes to determine in order to solicit the most desirable renewable energy resources that can be successfully integrated into our system without compromising reliability for our customers and at the same time maintaining reasonable costs. This RFP is structured to encourage Bidders to provide varying levels of pricing associated with meeting corresponding levels of performance standards. At the same time, HECO has been analyzing and preparing different cost models for operational and other modifications to accommodate differing levels of performance standards that Bidders may be able to provide. This combination of efforts

⁷ For example, many renewable projects, by their very nature, provide power on a variable basis, thus requiring offsetting firm generation as backup. Hawaii's island electric systems have difficulty accepting renewable generation during minimum load periods. Systems such as battery storage and pumped hydroelectric storage facilities allow a utility to accept and accommodate more as-available renewable energy.

will allow HECO's evaluation team to model differing combinations of Bidder's pricing and HECO's costs to determine an overall portfolio cost. For example, a proposal portfolio could involve a project developer including certain levels of proposed self-curtailment and/or some energy storage aspects to address ramp rate requirements. On the HECO side, operational adjustments could be implemented to provide additional response capability to minimize impacts of the intermittent source(s).

HECO recognizes that this approach creates added levels of complexity to the Bidder's proposal as required in the Response Package (Appendix B). At the same time, the challenges associated with ensuring Bidder's pricing information is accurately factored into the evaluation models by HECO is also recognized. For these reasons, HECO anticipates that during the course of the bid evaluations, it may be necessary for HECO to contact Bidders to either clarify their pricing and related proposed terms, or provide additional information to assist HECO in the evaluation. All such communications are intended to be coordinated under the review of the IO.

HECO extends its appreciation in advance to all Bidders and encourages Bidders to carefully review the Response Package and provide any necessary clarification to their proposed pricing specifically in response to meeting various levels of performance standards.

2.3 Performance Standards for Eligible Proposals

As a result of the previously mentioned integration challenges, HECO has developed performance standards that bidders are encouraged to design their projects to meet. As noted below in Chapter 4, bids will be evaluated in part on their ability to meet the performance standards identified in the model Purchase Power Agreement provided as Appendix C to the RFP.

HECO also recognizes that these Performance Standards have been derived based on achieving a penetration level to accommodate the grandfathered proposals, the projects acquired through this RFP, and additional renewable energy projects that may arise out of HECO's IRP-4. It is anticipated that renewable energy suppliers will initially be allowed to build their projects and sell energy with minimum levels of performance standards based on the initial low level of intermittent energy penetration on HECO's system. For example, if the first intermittent renewable energy project comes on line and is operational at 30 MWs, the performance standards may be negotiated in the PPA to be initially set to some lower level based on the corresponding lower level of initial penetration and pricing should reflect such initial conditions. However, as intermittent energy penetration levels increase as more non-firm resources enter the HECO system, adherence to the stricter performance standards will be required. The proposed model Purchase Power Agreement (PPA) includes contract language to address how HECO proposes to address the incorporation of both initial and future performance standards requirements. Bidders are encouraged to review these contract provisions carefully when preparing their proposal.

2.4 Pricing Formula Requirements

HECO will accept proposals from intermittent resources that offer one of the following pricing options:

- (1) a fixed price (in \$/MWh) for the term of the contract;

(2) a price (in \$/MWh) that escalates by a fixed escalation rate for the term of the contract (e.g. 2% per year); or by different fixed rates for various periods of the contract (e.g. 3% for the first 5 years, 2% for the next 5 years, etc.)

Bidders must provide pricing proposals for each of the applicable scenarios as requested in Section 4, Pricing Information in the Response Package (Appendix B). The PPA will be based on the selected level of performance standards during the bid evaluations and subsequent PPA negotiations.

2.5 Contract Energy

Bidders are required to provide their proposed Contract Energy (MWh) from their project in their proposal on the pricing sheets provided in the Bidders Response Package (Appendix B of this RFP). The model PPA Section 2 provides provisions for the purchase and sale of energy, rate for purchase and sale, and billing and payment. .

2.6 Bid Fees

Bidders are required to tender a bid fee of \$2,500 for each proposal submitted. This fee allows the Bidder to offer a base bid and one alternative option for the same proposal. Bidders who wish to offer additional alternatives will be required to pay additional bid fee(s). Alternative options could include a different pricing formula, proposal size, or in-service date. Proposals for a different site or technology would constitute a separate proposal and require an additional bid fee. This bid fee is non-refundable.

2.7 Contract Size

Bidders should prepare proposals for renewable energy contracts between 5 MW and no larger than 100 MW. Bids for contracts of 5 MWs or under on the HECO system are not subject to the Commission's Competitive Bidding Framework and may proceed to direct negotiations with HECO.

Bidders may elect to provide alternate proposals larger than 100 MW and may propose that these alternate proposals be incrementally phased in under a proposed implementation schedule. However, any proposal in excess of 100 MW is subject to the following:

Any bids received that are greater than 100 MWs, including bids with initial increments of less than 100 MWs, but which are contingent upon also being awarded subsequent phase(s) of generation greater than 100 MWs will be designated as non-conforming. Any Bidder who chooses to submit a non-conforming proposal must include sufficient justification and substantive information to allow a reasonable evaluation of (1) the anticipated impacts arising from the integration of the proposed project on the operation, reliability and power quality of the system, (2) the compliance of the proposed project with performance standards set forth in the RFP, and (3) the ability to implement the project, including all related interconnection facilities and infrastructure upgrades, within a reasonably defined and practical project development schedule. HECO will review procedures for addressing and/or responding to any such non-conforming proposals with the IO.

2.8 Power Purchase Agreement

A model PPA for renewable energy resources is attached as Appendix C. The model PPA has been prepared based on a wind project. The actual PPA may be modified as necessary based on the particular technology utilized. Bidders are required to review the PPA and provide a red-line version of the PPA with their requested changes, if any, as a component of their proposal. HECO will review and consider the requested changes and reflect the suggested changes in an overall risk assessment associated with each proposal. Bidders are discouraged from proposing fundamental changes to the risk allocation set forth in the model PPA. Bids that do not include proposed revisions to the attached PPA form will be deemed to have accepted the PPA terms.

Although HECO is seeking bids for non-firm or dispatchable/schedulable renewable energy, HECO is relying on the energy proposed to be delivered by bidders to meet RPS requirements. Bidders will be required to meet the general terms and conditions outlined in the form PPA with regard to the proposed commercial operation date of deliveries and project milestones, security requirements, liquidated damages for missing milestones, and contract default provisions.

As previously stated in Section 2.2 of this RFP, adherence to Performance Standards are important for maintaining reliability to HECO's customers. These Performance Standards have been identified in the attached model Power Purchase Agreement (Appendix C).

The model PPA also includes a provision to allow for addressing changes to Performance Standards, including, but not limited to, ramp rates, over the term of the contract (Section 23). The intent of this provision is to recognize that such changes to performance standards over time may allow HECO to more successfully integrate larger quantities of intermittent resources on the HECO system. By working cooperatively with bidders, HECO's intent is to provide a mechanism for flexibility in addressing these performance standards in future years. At the same time, HECO also understands such contract provisions may be of concern to developers and their investors and lenders. HECO believes that such concerns can be appropriately mitigated by including specific standards for considering changes to the performance standards and a pre-established process for resolving any disagreements between the parties.

Provisions for Delay damages and Events of Default are included in Section 13 of the PPA. Bidders should be aware that depending on the nature of the proposed project, if there is a long development period, HECO may consider including the Permit Application Filing Date and the Construction Start Date as guaranteed dates (in addition to the Commercial Operate Date per Section 13b) that could trigger Daily Delay Damages and Events of Default.

Chapter 3

Instructions to Bidders

3.1 Schedule for the Bidding Process

Chart 2 provides the proposed schedule for the bidding process. HECO reserves the right to revise the schedule as necessary. Any changes to the schedule will be posted on HECO's website.

Chart 2

RFP Schedule

Event	Anticipated Dates
Issue Draft RFP and Contract Forms	February 8, 2008
Prospective Bidders may submit initial questions	Thru Technical Conference
Technical Conference on RFP with Interested Parties.	Mid-March 2008*
Prospective Bidders File Comments on the Draft RFP	30 days from Technical Conference
HECO Files Proposed Final RFP and Contract Forms with the Commission	May 1, 2008
Independent Observer Submits Comments and Recommendations on the Proposed Final RFP	May 1, 2008
Opportunity for Participants to Comment on Proposed Final RFP and Independent Observer Recommendations	10 working days after Proposed Final RFP is filed
Commission Review and Approval of the Final RFP and Contract Forms	June 2, 2008
Final RFP Posted to the Company's Website	June 2, 2008
Bidders Conference Held	Mid-June 2008
Submit Notice of Intent to Bid	30 days from Final RFP Posting
Due Date for Proposals	September 4, 2008
Selection of Short-Listed Bidders	December 2008
HECO Completes Interconnection Studies for Short-Listed Bidders	June 2009
Selection of Award Group	August 2009
Execution of Contracts	December 2009
Submit Contracts for Commission Approval	December 2009

*Specific date to be provided when available

3.2 Technical Conference

As noted in the above schedule, prospective bidders and other non-bidding interested parties will have the opportunity to submit questions to HECO about the RFP prior to the Technical Conference in accordance with the above schedule.

HECO plans to hold a Technical Conference in accordance with the Framework for interested parties to discuss the provisions and requirements of the RFP and to address any issues with regard to the RFP. HECO encourages any party interested in bidding to attend the Technical Conference. Parties interested in attending the Technical Conference should check HECO's website for updates or further announcements on the time and location of the Technical Conference. Attempts will be made to accommodate parties who cannot attend in person to have the opportunity to call in to the Technical Conference. If possible, the call-in number will also be posted on the Generation Bidding website in advance of the date for the Technical Conference.

3.3 Submission of Comments With Respect to the Draft RFP and Proposed Final RFP

In accordance with the Framework, prospective bidders will have the opportunity to submit comments on the draft RFP as input to the completion of the final RFP. Comments should be submitted to the Commission (Docket No. 2007-0331), the HECO Official Contact and the Independent Observer. HECO will then determine whether to incorporate the recommendations of the parties and, if so, how to do so in a final, proposed RFP (including attachments). The IO will also review the comments of the parties. HECO will have the opportunity to address comments submitted by interested parties with the final proposed RFP filed with the Commission. The IO shall submit its comments and recommendations to the Commission concerning the RFP and all attachments at the same time the RFP is filed. Interested parties will have the opportunity to comment on the proposed final RFP and the IO's recommendations with respect to RFP terms that are different from those in the draft RFP; such comments would need to be filed within 10 working days of HECO's filing of the Proposed Final RFP. HECO shall have the right to issue the RFP if the Commission does not direct HECO to do otherwise within 30 days after the Commission receives the proposed RFP and the IO's comments and recommendations. The Commission will then review and approve the RFP prior to release of the final RFP document, with any modifications as may be directed by the Commission. Once approval is received, the Company will post the RFP on its website. It is estimated that the final RFP will be posted on the Company website on or about June 2, 2008.

3.4 Bidders Conference; Notice of Intent to Bid

Shortly after issuance of the Final RFP, HECO may hold a Bidders Conference to provide the opportunity to clarify any aspects of the RFP. Bidders may submit questions about the Final RFP prior to the Bidders Conference. HECO will attempt to answer questions submitted prior to and during the Bidders Conference. While HECO may respond orally to questions posed at the Bidders Conference, only written answers that are provided in response to written questions will be HECO's official responses.

Prospective bidders are also encouraged to submit a Notice of Intent to Bid form within 30 days of issuance of the Final RFP. See Appendix A for a copy of the Notice of Intent to Bid form. HECO

will provide updates by email regarding the RFP to prospective bidders who submit a Notice of Intent to Bid. Persons that submit a Notice of Intent to Bid are not obligated to submit a proposal.

3.5 Preparation of Proposals

Each Bidder shall have sole responsibility for carefully reviewing the RFP and all attachments and for thoroughly investigating and informing itself with respect to all matters pertinent to this RFP, its proposal and its anticipated performance under the PPA.

Bidders should rely only on information provided in the RFP and any associated written updates when preparing their proposal. Information submitted by bidders in response to the Solicitation of Interest will not be considered for this RFP unless re-stated in the proposal.

Each Bidder shall be solely responsible for and shall bear all of its costs incurred in the preparation of its proposal and/or its participation in this RFP, including, but not limited to, all costs incurred with respect to the review of the RFP documents, attending meetings with HECO, third party consultant consultation, and investigation and informing itself with respect to matters pertaining to its proposal and this RFP, and the same shall not be reimbursed by HECO to any Bidder, including the selected Bidder(s).

3.6 Submission of Proposals

Bidders must submit one original and five bound copies of their proposal as well as three CDs with the entire contents of the proposal to the HECO contact by 4:00 pm Hawaii time based on the schedule in Paragraph 3.1. Fax or email submissions will not be accepted. HECO reserves the right to reject any proposals received after the deadline. All copies of the proposal should be sent to the attention of the HECO Project Manager at the address listed below:

Ms. Colette Miller, MS-WA3/XB
Hawaiian Electric Company
P.O. Box 2750
Honolulu, Hawaii 96840

Proposals may be hand delivered to the attention of the Generation Bidding Project Manager at the following address:

Ms. Colette Miller, P.E.
Hawaiian Electric Company
820 Ward Avenue
Honolulu, Hawaii 96814

Each proposal shall contain the full name and business address of the Bidder and shall be signed by an authorized officer of the Bidder. Bidders may sign the original proposal and include copies of the signature page with the remaining proposals. All proposals submitted become the property of the Company.

3.7 Opening of Proposals

Proposals will be opened after the proposal due date at such date and time as HECO deems appropriate.

Proposals will be opened by HECO and/or Independent Observer personnel only, in private, and the Bidders shall not be present.

3.8 Exceptions

Bidders are required to submit a red-lined copy of the model PPA in Section 17 of the Response Package. Bidders are encouraged to state the rationale for their proposed changes to the model PPA. Bidders are discouraged from proposing fundamental changes to the risk allocation set forth in the model PPA.

HECO shall have the right to reject any proposal or evaluate it unfavorably based on the nature of the exceptions taken after consultation with the IO.

3.9 Description of the Evaluation Process

HECO will use a multi-stage evaluation process to review and evaluate proposals and to select the preferred resources. To proceed through each stage of the evaluation process, a proposal must meet established criteria. Chart 3 provides an illustration of the multi-stage evaluation process that will be used by HECO to review, evaluate and select proposals.

Chart 3

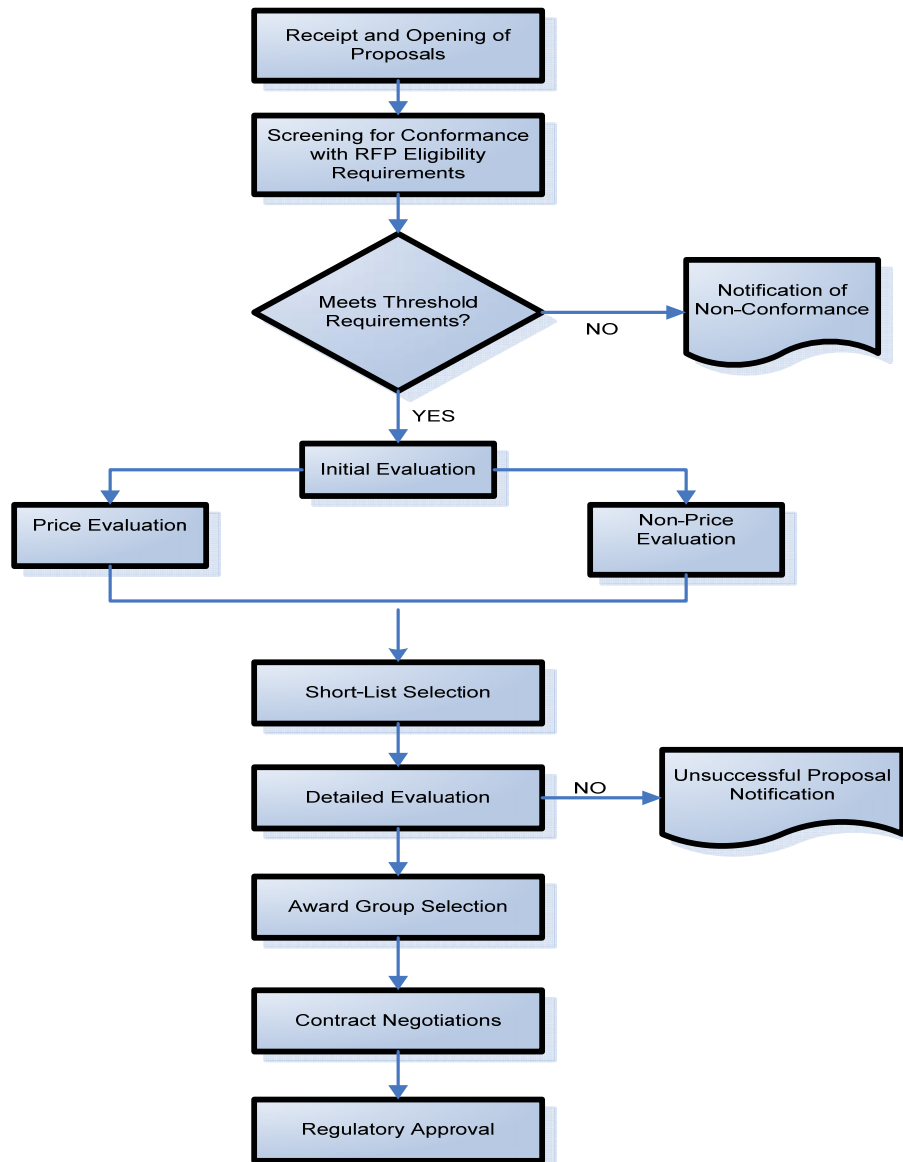

Each phase of the evaluation process is described in Section 4 of the RFP.

3.10 Confidentiality

Bidders must clearly identify all confidential information in their Proposals. However, Bidders should take care to designate as confidential only those portions of their Proposals that genuinely warrant confidential treatment. HECO discourages the practice of marking each and every page of a Proposal as “confidential.” HECO will make reasonable efforts to protect any such information that is clearly marked.

Bidders should note that HECO may be required to share certain confidential bid documents with parties involved in the RFP proceeding. A Protective Order Agreement for the handling of such confidential documents has been approved by the Commission. A copy of this approved Protective Order is posted on the website.

No Bidder shall be entitled to proposals from any other Bidder or any other information contained therein or provided by or with respect to any other Bidder.

3.11 Information on RFP Interconnection

HECO Tariff Rule 19, approved by the Commission, establishes provisions for Interconnection and Transmission Upgrades. See Appendix E. The tariff provisions are intended to simplify the rules regarding who pays for, installs, owns and operates interconnection facilities in the context of competitive bidding. The Tariff Rule 19 will be utilized as the basis for addressing interconnection and transmission upgrades for any projects developed through this RFP.

Bidders are required to include in their pricing proposal all costs between their *Generating Facility* and their proposed *Point of Interconnection* (see diagram from Rule 19 tariff).

The identification of the required facilities located between the proposed *Point of Interconnection* and the *Grid Interconnection Point* will be the subject of the Interconnection Requirements Study (IRS) for short listed bidders. For the purposes of the initial evaluation, Bidders are required to submit estimated costs for their preliminary assessment of these interconnection costs in the proposal Response Package. HECO recognizes that these costs are preliminary and subject to adjustments upon completion of the IRS. Bidders are also required to provide a Single Line Diagram with their proposal. In addition, Bidders are required to bid a \$/MWh amount per \$100,000 of actual interconnection costs. HECO will use the \$/MWh figure along with the Bidder's interconnection cost estimate (or, in HECO's discretion, HECO's estimate) in its economic analysis of the Bidder's proposal.

To assist Bidders with preparing these estimates, high-level unitized interconnection costs figures will be made available for use on HECO's Generation Bidding website after the RFP is approved and issued. All Bidders that submit a Notification of Intent to Bid will be notified when the cost data is available for their use.

The design of the interconnection facilities shall be in conformance with the Transmission Planning Criteria for facilities connected to the Transmission System (see Appendix A of HECO's Solicitation of Interest). HECO uses the breaker-and-a-half scheme for its transmission switching station as shown in Attachment A of Rule 19. Bidders should follow this scheme for their estimates.

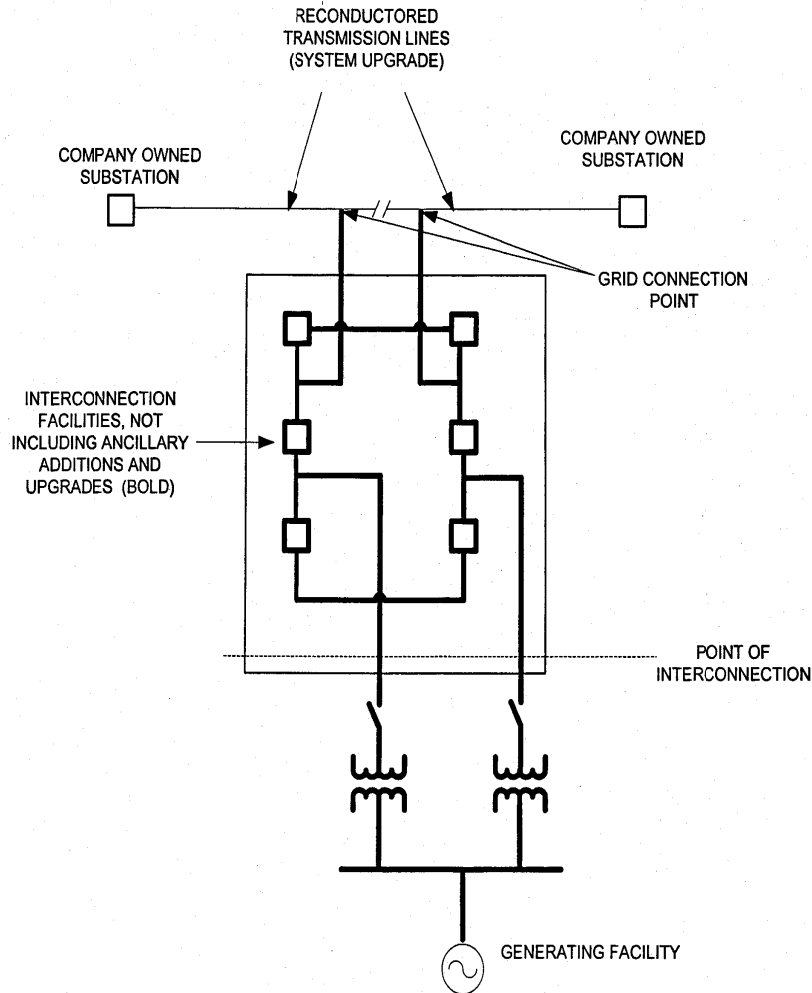

3.12 Credit Requirements

Bidders will be required to post security upon notification that they have been selected for the short-list (i.e., Bid Deposit Security). Bidders with whom HECO concludes contract negotiations of a PPA, bidders are required to post development period security upon execution of the PPA. Once a bidder's project achieves commercial operation, the development period security is exchanged for operating period security.

Within 10 days after formal notification that the bidder has been selected for the short-list, the bidder will be required to post a bid deposit security in the amount of \$3/kW based on the nominal capacity of the bid project proposal. A bidder who withdraws its proposal after notification of short-list selection will forfeit its deposit security. If a bidder is not selected for the award group, its bid deposit security will be returned.

Within 10 days of the Effective Date of the Contract, the Bidder will be required to post Development Period Security in the amount of \$30/kW. HECO will return the \$3/kW bid deposit security at the same time. Once the project achieves commercial operation, HECO will return the Development Period Security of \$30/kW to the Bidder. At the same time, the bidder will be required to post Operating Period Security of \$40/kW upon the commencement date of delivery. Operating Period Security will increase to \$50/kW for the last five years of the contract.

Bidders may meet the established security requirements through a letter of credit or cash collateral only.

Bidders will be required to post the levels of Development and Operating Period Security identified above. Alternatively, Bidders will be allowed to post higher levels of Development and Operating Period Security and identify such levels they are willing to post in Section 14 of the Response Package (Appendix B). Higher levels of security than the amount required will be relevant to HECO's consideration of the Non-Price Criteria – Project Operational Viability. See Chart 4 below. Section 14(l) of the form PPA provides proposed language should bidders choose to offer such additional security.

3.13 Modification or Cancellation of the RFP and Solicitation Process

HECO reserves the right to request additional information from Bidders at any time during the process. Bidders that are not responsive to such information requests may be eliminated from further consideration upon review with the IO. Unless otherwise expressly prohibited, HECO may, at any time up to final award, in consultation with the IO, postpone, withdraw and/or cancel this RFP; alter, extend or cancel any due date; and/or, alter, amend, withdraw and/or cancel any requirement, term or condition of this RFP, any and all of which shall be without any liability to HECO.

However, any action by HECO shall be subject to the provisions of the Framework, which require with respect to modifications to the RFP, review by the IO and submission to the Commission with 30 days notice before the modified RFP may be issued, unless the Commission directs otherwise (Section IV.B.10). HECO will follow the same procedure with regard to any potential postponement, withdrawal or cancellation of the RFP.

3.14 Organization of the Proposal

Bidders are required to organize their proposal consistent with the contents of the Response Package in Appendix B. The organization and contents of the proposal should be organized as follows:

1. Proposal Certification Form
2. Proposal Summary/Contact Information
3. Executive Summary
4. Pricing Information and Schedules
5. Project Operational Requirements
6. Energy Resource Plan
7. Financial/Legal
8. Siting
9. Environmental
10. Engineering and Technology

11. Operations and Maintenance
12. Project Schedule
13. Project Management/Experience
14. Security Provisions
15. Required Interconnection Technical Information
16. Alternatives
17. Redline Version of the PPA

Chapter 4

Evaluation Process and Evaluation Criteria

4.1 Bid Evaluation and Selection Process

Once the proposals are received, the proposals will be subject to a consistent and defined review, evaluation and selection process. This Chapter will provide a detailed description of each stage of the process along with the requirements of bidders at each stage. To be eligible to proceed through each stage of the process, bidders must meet the specified minimum requirements as outlined below.

4.2 Eligibility Requirements

Each proposal will be reviewed to ensure that it meets the Eligibility and Threshold requirements under this RFP. All proposals must meet the following Eligibility Requirements. Failure to meet any of these requirements could lead to disqualification of the proposal from further review and evaluation.

- The proposal must be received on time. Proposals received after the established due date will be subject to disqualification.
- The proposal must meet the minimum bid size of 5 MW of net output. The PUC's Competitive Bidding Framework does not apply to projects proposed for the HECO system that are 5 MW or less. Such projects may be submitted directly to HECO for consideration and do not have to participate in this competitive bidding process.
- The base proposal must not exceed a contractual amount of 100 MW and must be clearly distinguished from any alternate proposals.
- No proposals from HECO affiliates or subsidiaries will be eligible. Bidders must submit a certification with their proposal signed by a company officer or designated authority that this Bidder is not an affiliate or subsidiary of HECO or Hawaiian Electric Industries ("HEI").
- All proposals must be organized according to the structure identified in Chapter 3 and be consistent with the structure of the Response Package. Failure to provide all requested information may be cause for disqualification.
- The proposal submittal fee must be included with the proposal with the check made out to Hawaiian Electric Company. Failure to submit the fee with a proposal may be cause for disqualification.
- The proposal must be signed and certified by an officer or other authorized person of the Bidder.

4.3 Threshold Requirements

Bids that meet all the Eligibility Requirements will then be evaluated to determine compliance with threshold requirements which have been designed to screen out proposals that are insufficiently developed, lack demonstrated technology or will impose unacceptable financial accounting consequences for HECO. The Threshold Requirements for this RFP are the following:

- **Site Control**

The Bidder must demonstrate that it has control or a right to acquire control over a site for its project. To meet this threshold requirement, bidders must either provide documentation indicating that they own the site on which the project will be located, have an option agreement on the site, or at a minimum have negotiated a letter of intent for the site. HECO understands that site approval documents at this preliminary stage may be conditional upon receipt of a PPA from HECO. Proposals with no demonstration of site control will be rejected.

- **Experience of the Bidder**

The Bidder, its affiliated companies, and/or its partners (which may include affiliates of a member or members of a limited liability company that is the bidder) must have experience in the development and operation of at least one electricity generation project similar to the project being proposed.

- **Technical Maturity**

HECO is seeking proposals for generation technologies that have reached a proven level of technological maturity and must be demonstrated or commercially available. Bidders should be able to provide evidence that a technology is commercially available or demonstrated to be feasible in commercial operations by providing examples of cases where such a technology has been successfully utilized.⁸

- **Variable Interest Entity Treatment**

HECO is not willing to be subject to accounting treatment that results from variable interest entity (“VIE”) treatment as set forth in Financial Accounting Standards Board Interpretation No. 46 (revised December 2003) (“FIN 46”). Bidders are required to demonstrate, with supporting information to allow the Company to verify such conclusion, that the proposal will not result in the seller under the power purchase agreement being a VIE that would trigger consolidation of seller’s finances on to HECO’s balance sheet under FIN 46. If HECO believes that the proposal may be subject to such treatment, it will inform the Bidder and the IO and either may request additional information or work with the Bidder to structure the proposed power purchase agreement and/or the generation entity to avoid VIE treatment.

⁸ Please note that separate from this procurement effort, HECO is considering the integration of emerging renewable energy technologies, such as wave energy, into the grid. As stated in HECO’s IRP-3 Evaluation Report, the Company has envisioned the potential for a “set-aside” for up to 20 MW of non-firm energy from emerging renewable technologies. HECO is developing a separate procurement strategy for these emerging renewable energy resources. A procurement strategy will be the subject of analysis in HECO IRP-4.

HECO reserves the right to allow a proposal to proceed through the evaluation process through selection of the short-list and work with the Bidder on this issue during the period in which HECO is conducting interconnection studies for the bidders. If HECO and the Bidder cannot resolve VIE issues during this timeframe, HECO reserves the right to reject the bid as not conforming to the threshold criteria after consultation with the IO.

- **Credit/Collateral Requirements**

The bidders must agree to post Development Period Security of no less than \$30/kW and Operating Period Security of no less than \$40/kW.

4.4 Initial Evaluation – Price and Non-Price Analysis

Proposals that meet the Threshold Requirements will then be subject to an initial price and non-price analysis. The results of the price and non-price analysis will be a relative ranking and scoring of all proposals. Pricing related criteria are generally expected to be weighted higher than non-pricing criteria. Chart 4 provides the general components of the price and non-price evaluation criteria that will be included in the initial evaluation, but it is not necessarily an exhaustive list of all criteria.

HECO will be employing a closed bidding process for this solicitation in accordance with Section IV.H.3 of the Competitive Bidding Framework. The specific weights of the evaluation criteria will not be provided in the RFP or disclosed in advance. The price and non-price evaluation models to be used will not be provided to Bidders, but will be reviewed with the IO and will be documented prior to the opening of any bid proposals. In addition, all input assumptions for the analysis will be provided to the IO and will be secured prior to receipt of bids.

HECO is proposing to follow an evaluation process that allows for flexibility in the non-price evaluation criteria weighting in accordance with Section IV.E.10 of the Competitive Bidding Framework to provide consideration for the complexity of the evaluation of the degree of conformity with the performance standards in the bids received, anticipated diversity of the types of proposals that will be received (technology type, location, etc.), and challenges associated with developing overall system cost impacts of the various portfolios of resources that may be considered. Any potential modifications to the criteria or criteria weighting to reflect unanticipated considerations or refinement of the evaluation model will be addressed with the IO prior to proceeding.

Chart 4

Initial Price and Non-Price Evaluation Criteria

Evaluation Criteria	Factors
Price Criteria	
1. Bid Price/System Impacts	<ul style="list-style-type: none"> • Cost of Energy • Expected Schedule of Energy to be Delivered • Cost of Imputed Debt • Transmission System or Distribution System Upgrade Costs

Non-Price Criteria	
1. Project Development Feasibility	<ul style="list-style-type: none"> • Site Status • Community Support • Status of Permits • Critical Path Schedule • Engineering Design • Financing Plan • Experience of Bidder • Fuel/Energy Supply Status • Viability of Technology
2. Project Operational Viability and Financial Support	<ul style="list-style-type: none"> • Bidder Credit Rating • Financial Strength of the Bidder and Project • Additional Security Offered • Environmental Impacts • O&M Plan
3. Operating Profile	<ul style="list-style-type: none"> • Conformance with Performance Standards • Impacts on System Operations • Generation Profile • Coordination of Maintenance
4. Flexibility	<ul style="list-style-type: none"> • Bid Size • Commercial Operation Date • Contract Provisions for Performance Standards

4.4.1 Initial Evaluation Using Price Related Evaluation Criteria

The price evaluation will be based on the total net cost to the utility of integrating a bidder's proposed project onto the utility's grid and purchasing the renewable energy from the bidder at the bidder's proposed price.⁹ Proposals will be compared to each other in this phase of the evaluation based on the methodology and cost components described below. The total net system cost analysis will include a calculation of the utility's fuel cost savings and any other direct savings resulting from the displacement of generation by the proposed project. The components of the total net cost to the utility for each proposal will include:

4.4.1.1 the cost of the energy to be purchased as a product of the bid price and the Contract Energy based on the generation profile submitted by the bidder;

4.4.1.2 the estimated increase in operating cost, if any, incurred by the utility to maintain grid reliability. This may include the cost of an increased level of spinning reserve

⁹ Should HECO receive a large number of bids, HECO reserves the right to conduct the initial price evaluation using a real levelized cost analysis based on the bid price formula only for each proposal as an initial price screen.

to maintain grid reliability and the reduction in system fuel efficiency as fossil fueled generating units may need to operate at lower efficiency points in order to accommodate the renewable generation;

4.4.1.3 transmission system or distribution system upgrade costs, if any, beyond the Grid Interconnection Point that would be incurred by the utility if it integrates the Bidder's project onto the utility grid; and

4.4.1.4 savings due to reduction in fuel costs and other costs associated with the displacement of energy by the proposed project; and

4.4.1.5 the cost of capital structure rebalancing resulting from imputed debt, if any.

4.4.1.6 Cost of Imputed Debt

The utility will take into account the cost of rebalancing the Company's capital structure resulting from any debt or imputed debt impacts associated with each proposal. If bidders submit proposals that are responsive to the terms of the RFP with respect to term (20 years) and pricing structure (fixed prices per MWh with no capacity payments), HECO proposes to use the imputed debt methodology published by Standard & Poor's (S&P) that is applicable to power purchase agreements of this type since they would not normally be treated as leases for accounting purposes.¹⁰ HECO anticipates that proposals submitted in response to this RFP will not be classified as capital leases. Therefore, HECO expects that S&P's published guidance will apply for calculation of the imputed debt impacts.

HECO proposes to apply a risk factor consistent with guidance from S&P regarding the risk factor that would be applicable to HECO's entering into the particular type of PPA and the cost-recovery mechanism available to HECO. Under current guidance from S&P, HECO plans to use a risk factor of 25 percent in light of the power cost adjustment recovery provisions available to PPAs that HECO would expect to enter into pursuant to the RFP.¹¹ For resources where the contract price is stated as a single, all-in energy price (e.g. intermittent resource), S&P has recently published a revised methodology which calculates the fixed costs for imputed debt purposes based on a proxy capacity charge stated in \$/kW-year for a combustion turbine peaking unit.

¹² The costs of increasing equity (and corresponding decrease in debt) to maintain the

¹⁰ Each proposal will be evaluated under generally accepted accounting standards, to determine whether or not it is a lease. If the proposal is deemed to be a lease, it will be evaluated to determine whether it is an operating lease or a capital lease obligation. If the proposal is deemed a capital lease obligation, the incremental cost of additional common equity to maintain the Company's target equity/total capitalization ratio will be considered in the proposal evaluation. If the proposal is deemed an operating lease or other off-balance sheet obligation, HECO proposes to use the imputed debt methodology published by Standard & Pools. HECO expects that proposals submitted in conformance with the requirements of this RFP would be treated as a power purchase agreement rather than a lease for accounting purposes.

¹¹ See Standard & Poor's Methodology for Imputing Debt for U.S. Utilities' Power Purchase Agreements (May7, 2007).

¹² Ibid.

target equity/total capitalization ratio which the Company expects without the new purchase power agreement will be calculated using the Company's incremental cost of capital and capital structure weights from its most recent rate case interim or final order.

4.4.1.7 Transmission or Distribution System Upgrade Costs

In accordance with Section 4 of the Appendix B (Response Package) to the RFP, Bidders are required to provide a bid \$/MWh adder to the contract price based on actual interconnection costs as well as their estimated interconnection costs up to the Grid Interconnection Point. The resulting estimated \$/MWh amount shall be factored into the Bidder's pricing provided in Section 4 of Appendix B to the RFP. HECO reserves the right to adjust Bidders estimates for interconnection costs if estimates provided by Bidders are determined by HECO to be incorrect or deficient and will use its estimate multiplied by the \$/MWh formula proposed by Bidder in its economic evaluation.

4.4.1.8 Initial Cost Ranking

Bidders' projects will be ranked from lowest to highest net cost (or savings) on a dollars per MWh basis based on the result derived through the application of the methodology described above. HECO may forego the system impact analysis if it is clear that the cost-only analysis is conclusive regarding a particular proposal.

4.4.2 Initial Evaluation of the Non-Price Related Criteria

Chart 4 provides a list of the non-price categories. Within each category are a number of sub-criteria that will be considered in the evaluation. This section of the RFP will identify and describe in more detail the sub-criteria within each primary category.

4.4.2.1 Project Development Feasibility Criteria

This category is designed to assess the likelihood of a project coming to fruition based on various factors critical to successful project development. The status of development as well as the likelihood of timely project completion will be evaluated. The objectives of the criteria within this category are to provide an indication of the feasibility and viability of each project and the likelihood of meeting the proposed commercial operation date. HECO prefers proposals from bidders that can demonstrate based on the current status of project development and past experience that the project will likely be successfully developed as proposed. The following factors/considerations will be considered in assessing the development feasibility of each proposal:

- Site status, right-of-way acquisition and need for zoning;
- Effectiveness of the community relations plan and status of any local or community support;
- Status/identification of the environmental permits and an identification of the approving agency for each permit required for project development;

- A detailed critical path schedule for the project that clearly identifies the critical path elements and demonstrates that the project can meet its scheduled commercial operation date;
- A detailed description of the technology proposed as well as a description of the engineering design and equipment requirements, equipment availability, and the performance of the equipment in other applications;
- A detailed plan to finance the project, including the sources of debt and equity;
- A detailed demonstration, including any supporting studies, regarding the energy generation resources and generation profile underlying the proposal;
- Demonstration of the experience and capabilities of the project management team in successfully developing, financing and operating other similar projects, particularly in utility systems similar to HECO;
- Demonstration of access to any resource inputs or commodities including access to adequate water supplies, labor services, etc.; and
- Requirements to construct additional transmission infrastructure and the expected impacts on commercial operational date certainty.

4.4.2.2 Project Operational Viability Criteria

Project operational viability characteristics provide a means of evaluating whether Bidders are likely to provide reliable service to HECO and its customers over the term of the PPA. Two financial aspects in this evaluation are the financial strength of the bidder and the financial viability of the project. HECO prefers proposals from entities with investment grade ratings and proposals that clearly demonstrate the financial viability of the project. The following factors will be considered in assessing the project operational viability of each proposal:

- Operation and maintenance plan, including the reasonableness of the maintenance funding levels and arrangements, the willingness of a Bidder to execute a long-term contract with a reputable O&M provider and the previous experience of the Bidder in maintaining and operating similar facilities;
- Credit rating of the Bidder or of any affiliated entity;
- Level and type of security offered by the Bidder;
- Demonstration of the financial strength of the Bidder and the viability of the project to remain financially strong. Bidders should note that short-listed bidders will be required to provide a financial pro-forma for their project; and
- Environmental compliance and impacts (air, water, land, aesthetics, wildlife).

4.4.2.3 Operating Profile Criteria

Operating profile criteria are designed to evaluate the system impacts associated with each project relative to the level of consistency with operational performance requirements. These include frequency regulation and potential resource curtailment. HECO prefers proposals that conform to HECO's performance standards and offer system operational flexibility. The following factors will be considered in assessing the operational performance requirements:

- Willingness of the Bidder to coordinate the maintenance schedules of its project in conjunction with the Company's maintenance schedules for its own units;

- Impacts on system operations and maintenance of system stability including optimizing unit scheduling, frequency control, voltage control, and system management;
- Generation profile or expected schedule of energy to be delivered. The intent of this factor is to recognize that the same quantities of energy can have different value to the utility, depending on when they are delivered (i.e., MWhs delivered between 6:00pm and 7:00pm or 12:00noon and 1:00pm are typically more “valuable” to the utility than MWhs delivered between 3:00am and 4:00am);
- Conformance with HECO’s Performance Standards; and
- Ability to provide forecasted availability, scheduled energy capability, and dispatchability.

4.4.2.4 Flexibility Criteria

Flexibility provisions are designed to assess enhancements to project value to HECO based on the ability and willingness of the Bidder to offer provisions of value to HECO and its customers. The following criteria are considered in this category:

- Bid size (HECO may prefer contracts in an output range sufficient to allow HECO to contract with more than one project entity to diversify project risk);
- In-service date (HECO prefers projects that reasonably propose a commercial operation date in the 2010-2012 timeframe);
- Location of proposed project on the utility grid; and
- Willingness to accept contract provisions for flexibility to accommodate future changes to performance standards.

4.5 Selection of the Initial Short List

The specific evaluation process followed under the Short List Selection Process will depend on the number of proposals received. Proposals will be evaluated relative to one another and relative to their impact on HECO’s system using the price and non-price criteria identified above. While the total price and non-price rankings will serve as the basis of evaluation, HECO reserves the right to select a short list that could include a diversity of resource characteristics, project sizes and other options to provide a more well-rounded portfolio of renewable resources.

Due to the complexity of evaluating the different size and types of resources, as well as the anticipated varying ability of project proposals meeting the performance standards, HECO is interested in maintaining flexibility in the Short List Selection process. HECO will work with the IO to develop a detailed evaluation and selection process and methodology. The process and methodology will be established prior to receipt of bids. HECO reserves the right to have a reasonable degree of flexibility in implementation of the evaluation and selection process, subject to consultation with, and review by, the IO.

HECO may select a short list that includes more proposals than HECO expects to include in a final award group to ensure a viable competitive process is followed. HECO reserves the right to solicit additional bids from bidders after reviewing the initial bids, as provided in Section IV.B.10 of the Framework. Projects selected for the shortlist will be required to provide bid deposit security (see Section 3.12 of this RFP).

4.6 Detailed Evaluation

Bids selected for the short-list will be subject to a more detailed assessment concurrent with and following the conduct of the interconnection and system impact studies by the Company. The detailed evaluation will also include a risk assessment of the bids on the short list to assess in more detail the viability of each proposal as well as a sensitivity analysis of key factors influencing project economics. At this point in the process, the Company may elect to have face-to-face meetings with bidders to better allow the Company to assess the Bidder's proposal and the status of the project.

Once the detailed evaluation of the pricing proposals are completed and verified for all Short List Bidders, HECO will perform a portfolio type analysis using complex pricing models that are intended to examine different combinations of Bidder's pricing proposals, adjusted as necessary for the various ramp rate scenarios, with and without varying combinations of utility system costs. This evaluation model and approach on conducting portfolio analyses will be reviewed with the IO before the evaluation is conducted and the results will be reviewed with the IO prior to selection of the Final Award Group.

The objective of the evaluation is to select the Proposal(s) which provide the greatest value consistent with the Company's stated objectives and requirements as set forth in the RFP. The preferred Proposal(s) do not necessarily have to be the lowest cost option(s) or have the most favorable non-price factor evaluation. The Company prefers viable projects which provide low cost with limited risk and provide resource diversity, operational reliability, operational flexibility, and ability to meet the required Performance Standards. Ranking of the projects will be based on a variety of these and related factors. HECO does not expect that any single project will necessarily have the best attributes in each of the evaluation categories.

4.7 Selection of the Final Award Group

Based on the results of the detailed evaluation and review with the IO as described above, HECO will select a Final Award Group from which to begin contract negotiations. All bidders will be notified at this stage of the evaluation process whether their proposal is included in the Final Award Group. However, proposal evaluation results and rankings will not be disclosed to the bidders in the Final Award Group.

4.8 Contract Negotiation Process

Bidders selected for the Final Award Group will be required to indicate in writing to HECO's Official Contact whether they intend to proceed with their proposals within 5 business days of being notified by HECO of its intent to enter into contract negotiations. HECO will focus on negotiations first with the highest ranked proposals sufficient to meet the objectives of the RFP. If negotiations with these bidders indicate that HECO is unlikely to successfully negotiate acceptable terms with the Bidders within the period allotted for negotiations and after review with the IO, HECO reserves the right to put negotiations on hold with the Bidder and focus on negotiations with a lower ranked Bidder.

4.9 Regulatory Approval

Based on the Framework, the Commission will review and approve or deny approval of the Power Purchase Agreements that result from the RFP. In reviewing such contracts, the Commission may establish review processes that are appropriate to the specific circumstances of each solicitation.

**APPENDIX A
NOTICE OF INTENT
(CONFIDENTIAL)**

1 Company Name: _____

2 Contact Person Information:

Name	
Title/Position	
Mailing Address	
Courier Address (if different)	
Telephone Number	
Fax Number	
E-mail Address	

3 Type of Project or Bid Expected to be Proposed: _____

4 Location, Size (MW) and Interconnection Point of Project (if available): _____

5 Name: _____

Title: _____ Date: _____

This Notice of Intent may be submitted electronically to HECO's Generation Bidding Division at genbid@heco.com or mailed to the Generation Bidding Project Manager (MS-WA3/XB), at Hawaiian Electric Company, P.O. Box 2750, Honolulu, Hawaii 96840. Receipt of the Notice of Intent will be confirmed in an e-mail from Hawaiian Electric to the Bidder.

This form should be delivered to the above address within 30 days from issuance of the Final RFP.

Appendix B

Response Package

1. Proposal Certification Form

Authorized Applicant's Signature and Acceptance Form

The undersigned is a duly authorized representative of the Proposer listed below. The Bidder hereby certifies that all the statements and representations made in this Proposal are true and accurate to the best of the Bidder's knowledge. The Bidder represents that it understands the requirements, terms, and conditions of the RFP.

The Bidder hereby certifies that the Bidder is not an affiliate or subsidiary of Hawaiian Electric Company, Inc. or Hawaiian Electric Industries, Inc. (see Section 4.2 of the RFP).

The prices, terms and conditions of this Proposal are valid through selection of the award group.

Submitted by: _____
(Exact legal name of Company)

Bidder _____
(if different than above)

Signature of an Officer
Of Bidder _____

Print or type name of
Officer _____

Title: _____

Date Signed: _____

2. Proposal Summary/Contact Information

Project Name: _____

Proposed In-Service Date: _____

Bidder Name: _____

Project Site/Location:
City or Town: _____

Proposed Interconnection Point _____

Project Contact:
Name: _____
Address: _____

Phone Number: _____
Email Address: _____
Facsimile Number: _____

Gross and Net Capability
Of the Facility (kW):
Gross: _____
Net: _____

Annual Contract Energy (MWh): _____

Term of Contract: _____

Estimated Plant Life _____

Technology (Wind, landfill gas,
Solar photovoltaics, hydro, etc.)¹³ _____

Equipment Manufacturer _____

Energy Source _____

¹³ The technology or resource type should be consistent with the eligible resource options under the RPS requirements as listed in Section 1.2.

Project Type (check all applicable) _____ Non-Firm Intermittent Energy
_____ Schedulable Energy
_____ Dispatchable Energy

Number of Generators, Size _____
And Type (synchronous, induction, other)

3. Executive Summary of the Proposals

- a. The Bidder is required to provide an executive summary of the project proposal in this Section of the Response Package. The Bidder should include a description of the important elements of the proposal consistent with the sections outlined in the Table of Contents included in the Response Package. Bidders should provide sufficient information to clearly demonstrate how their proposal conforms to the eligibility and threshold criteria specified in Sections 4.2 and 4.3 of the RFP.
- b. Status of project activities to date.
 - Please discuss the developer's activities relative to the project undertaken to date.
- c. Security Offered:
 - Nominal Project Capacity: __ kW
 - Bid Deposit Security: \$3/kW required: \$_____
 - Project Development Security: \$30/kW required: \$_____
 - Operational Period Security: \$40/kW initially: \$_____
 - Form of Security: Letter of Credit: _____
Cash: _____

4. Pricing Information

Bidders are required to complete a Pricing Schedule for each applicable Scenario listed below. Pricing is separated for wind farm proposals 50 MW and under, wind farm proposals between 50 MW and 100 MW, and non-wind farm proposals. Proposals for the sale of energy from planned wind farms are required to include pricing proposals for each of the eight performance scenarios specified below based on project size, while proposals based on other technologies are required to include pricing proposals for the four scenarios specified below. Pricing submittal sheets follow.

Pricing Scenarios A1-D1: Applies to Wind Farm Projects Less than 50 MW
<p>Scenario A1 (Base)</p> <ul style="list-style-type: none">• Maximum Ramp Rate Upward of 2.0 MW/minute for all periods except during Early Morning Low-Load Periods (typically Midnight to 4:00 am) where Maximum Ramp Rate Upward is 1 MW/minute• Maximum Ramp Rate Downward of 2.0 MW/minute for all periods except during Evening Periods (typically 4:00 pm to 8:00 pm) where Maximum Ramp Rate Downward is 1 MW/minute• Maximum Sustained Ramp Rate Upward or Downward of 10 MW per 10 minute period• Continuous compliance with Frequency Regulation Performance Standard in Model PPA, Appendix B, Section 3.m.
<p>Scenario B1 (On-Call Frequency Regulation)</p> <ul style="list-style-type: none">• Same as Scenario A1 with the exception of only requiring compliance with the Frequency Regulation Performance Standard in Model PPA, Appendix B, Section 3.m. on an On-Call basis only in response to system underfrequency situations as determined by HECO System Operations. Limited to ____ hours per year.
<p>Scenario C1 (Exception to Ramp Down for Wind Drop-off events)</p> <ul style="list-style-type: none">• Same as Scenario A1 with the exception that the specified Maximum Downward Ramp Rates would only apply when operationally feasible (i.e., would not apply in situations where there is a drop off of wind)
<p>Scenario D1 (On-Call Frequency Regulation and Exception to Ramp Down for Wind Drop-off events)</p> <ul style="list-style-type: none">• Same as Scenario B1 with the exception that the specified Maximum Downward Ramp Rates would only apply when operationally feasible (i.e., would not apply in situations where there is a drop off of wind)

Pricing Scenarios A2-D2: Applies to Wind Farm Projects Less than 50 MW

Scenario A2 (Maximum Up/Down Ramp Rate of 2 MW/minute)

- Maximum Ramp Rate Upward of 2.0 MW/minute for all periods
Maximum Ramp Rate Downward of 2.0 MW/minute for all periods
- Maximum Sustained Ramp Rate Upward or Downward of 10 MW per 10 minute period
- Continuous compliance with Frequency Regulation Performance Standard in Model PPA, Appendix B, Section 3.m.

Scenario B2 (On-Call Frequency Regulation)

- Same as Scenario A2 with the exception of only requiring compliance with the Frequency Regulation Performance Standard in Model PPA, Appendix B, Section 3.m. on an On-Call basis only in response to system underfrequency situations as determined by HECO System Operations. Limited to ____ hours per year.

Scenario C2 (Exception to Ramp Down for Wind Drop-off events)

- Same as Scenario A2 with the exception that the specified Maximum Downward Ramp Rates would only apply when operationally feasible (i.e., would not apply in situations where there is a drop off of wind)

Scenario D2 (On-Call Frequency Regulation and Exception to Ramp Down for Wind Drop-off events)

- Same as Scenario B2 with the exception that the specified Maximum Downward Ramp Rates would only apply when operationally feasible (i.e., would not apply in situations where there is a drop off of wind)

Pricing Scenarios AA1-DD1: Applies to Wind Farm Projects Between 50 MW and 100 MW

Scenario AA1 (Maximum Up/Down Ramp Rate of 2 MW/minute)

- Maximum Ramp Rate Upward of 2.0 MW/minute for all periods
Maximum Ramp Rate Downward of 2.0 MW/minute for all periods
- Maximum Sustained Ramp Rate Upward or Downward of 20 MW per 10 minute period
- Continuous compliance with Frequency Regulation Performance Standard in Model PPA, Appendix B, Section 3.m.

Scenario BB1 (On-Call Frequency Regulation)

- Same as Scenario AA1 with the exception of only requiring compliance with the Frequency Regulation Performance Standard in Model PPA, Appendix B, Section 3.m. on an On-Call basis only in response to system underfrequency situations as determined by HECO System Operations. Limited to ____ hours per year.

Scenario CC1 (Exception to Ramp Down for Wind Drop-off events)

- Same as Scenario AA1 with the exception that the specified Maximum Downward Ramp Rates would only apply when operationally feasible (i.e., would not apply in situations where there is a drop off of wind)

Scenario DD1 (On-Call Frequency Regulation and Exception to Ramp Down for Wind Drop-off events)

- Same as Scenario BB1 with the exception that the specified Maximum Downward Ramp Rates would only apply when operationally feasible (i.e., would not apply in situations where there is a drop off of wind)

Pricing Scenarios AA2-DD2: Applies to Wind Farm Projects Between 50 MW and 100 MW

Scenario AA2 (Maximum Up/Down Ramp Rate of 3 MW/minute)

- Maximum Ramp Rate Upward of 3.0 MW/minute for all periods
Maximum Ramp Rate Downward of 3.0 MW/minute for all periods
- Maximum Sustained Ramp Rate Upward or Downward of 20 MW per 10 minute period
- Continuous compliance with Frequency Regulation Performance Standard in Model PPA, Appendix B, Section 3.m.

Scenario BB2 (On-Call Frequency Regulation)

- Same as Scenario AA2 with the exception of only requiring compliance with the Frequency Regulation Performance Standard in Model PPA, Appendix B, Section 3.m. on an On-Call basis only in response to system underfrequency situations as determined by HECO System Operations. Limited to ____ hours per year.

Scenario CC2 (Exception to Ramp Down for Wind Drop-off events)

- Same as Scenario AA2 with the exception that the specified Maximum Downward Ramp Rates would only apply when operationally feasible (i.e., would not apply in situations where there is a drop off of wind)

Scenario DD2 (On-Call Frequency Regulation and Exception to Ramp Down for Wind Drop-off events)

- Same as Scenario BB2 with the exception that the specified Maximum Downward Ramp Rates would only apply when operationally feasible (i.e., would not apply in situations where there is a drop off of wind)

Applies to Non-Wind Farm Projects

- Maximum Ramp Rate Upward of 2.0 MW/minute for all periods except during Early Morning Low-Load Periods (typically Midnight to 4:00 am) where Maximum Ramp Rate Upward is 1 MW/minute
- Maximum Ramp Rate Downward of 2.0 MW/minute for all periods except during Evening Periods (typically 4:00 pm to 8:00 pm) where Maximum Ramp Rate Downward is 1 MW/minute
- Maximum Sustained Ramp Rate Upward or Downward of 10 MW per 10 minute period
- Continuous compliance with Frequency Regulation Performance Standard in Model PPA, Appendix B, Section 3.m.

Wind Farms 50 MW and Under Only

Scenario A1 (Base)

Option 1 – Fixed Price \$/MWh: _____

Option 2 – Pricing with Escalation			
Year	Annual Contract Energy (MWh)	Bid Price \$/MWh w/ Escalation	Escalation Rate Applied
2008			
2009			
2010			
2011			
2012			
2013			
2014			
2015			
2016			
2017			
2018			
2019			
2020			
2021			
2022			
2023			
2024			
2025			
2026			
2027			
2028			
2029			
2030			
2031			
2032			
2033			
2034			
2035			

\$ _____/MWh adder per additional \$100,000 of actual costs for construction of facilities between the Point of Interconnection and Grid Interconnection Point.

Wind Farms 50 MW and Under Only

Scenario B1 (On-Call Frequency Regulation)

Option 1 – Fixed Price \$/MWh : _____

Option 2 – Pricing with Escalation			
Year	Annual Contract Energy (MWh)	Bid Price \$/MWh w/ Escalation	Escalation Rate Applied
2008			
2009			
2010			
2011			
2012			
2013			
2014			
2015			
2016			
2017			
2018			
2019			
2020			
2021			
2022			
2023			
2024			
2025			
2026			
2027			
2028			
2029			
2030			
2031			
2032			
2033			
2034			
2035			

\$ _____/MWh adder per additional \$100,000 of actual costs for construction of facilities between the Point of Interconnection and Grid Interconnection Point.

Wind Farms 50 MW and Under Only

Scenario C1 (Exception to Ramp Down for Wind Drop-off events)

Option 1 – Fixed Price \$/MWh : _____

Option 2 – Pricing with Escalation			
Year	Annual Contract Energy (MWh)	Bid Price \$/MWh w/ Escalation	Escalation Rate Applied
2008			
2009			
2010			
2011			
2012			
2013			
2014			
2015			
2016			
2017			
2018			
2019			
2020			
2021			
2022			
2023			
2024			
2025			
2026			
2027			
2028			
2029			
2030			
2031			
2032			
2033			
2034			
2035			

\$ _____/MWh adder per additional \$100,000 of actual costs for construction of facilities between the Point of Interconnection and Grid Interconnection Point.

Wind Farms 50 MW and Under Only

Scenario D1 (On-Call Frequency Regulation and Exception to Ramp Down for Wind Drop-off events)

Option 1 – Fixed Price \$/MWh : _____

Option 2 – Pricing with Escalation			
Year	Annual Contract Energy (MWh)	Bid Price \$/MWh w/ Escalation	Escalation Rate Applied
2008			
2009			
2010			
2011			
2012			
2013			
2014			
2015			
2016			
2017			
2018			
2019			
2020			
2021			
2022			
2023			
2024			
2025			
2026			
2027			
2028			
2029			
2030			
2031			
2032			
2033			
2034			
2035			

\$ _____/MWh adder per additional \$100,000 of actual costs for construction of facilities between the Point of Interconnection and Grid Interconnection Point.

Wind Farms 50 MW and Under Only

Scenario A2 (Maximum Up/Down Ramp Rate of 2 MW/minute)

Option 1 – Fixed Price \$/MWh : _____

Option 2 – Pricing with Escalation			
Year	Annual Contract Energy (MWh)	Bid Price \$/MWh w/ Escalation	Escalation Rate Applied
2008			
2009			
2010			
2011			
2012			
2013			
2014			
2015			
2016			
2017			
2018			
2019			
2020			
2021			
2022			
2023			
2024			
2025			
2026			
2027			
2028			
2029			
2030			
2031			
2032			
2033			
2034			
2035			

\$ _____/MWh adder per additional \$100,000 of actual costs for construction of facilities between the Point of Interconnection and Grid Interconnection Point.

Wind Farms 50 MW and Under Only

Scenario B2 (2 MW Ramp Rate w/ On-Call Frequency Regulation)

Option 1 – Fixed Price \$/MWh : _____

Option 2 – Pricing with Escalation			
Year	Annual Contract Energy (MWh)	Bid Price \$/MWh w/ Escalation	Escalation Rate Applied
2008			
2009			
2010			
2011			
2012			
2013			
2014			
2015			
2016			
2017			
2018			
2019			
2020			
2021			
2022			
2023			
2024			
2025			
2026			
2027			
2028			
2029			
2030			
2031			
2032			
2033			
2034			
2035			

\$ _____/MWh adder per additional \$100,000 of actual costs for construction of facilities between the Point of Interconnection and Grid Interconnection Point.

Wind Farms 50 MW and Under Only

Scenario C2 (2 MW Ramp Rate w/ Exception to Ramp Down for Wind Drop-off events)

Option 1 – Fixed Price \$/MWh : _____

Option 2 – Pricing with Escalation			
Year	Annual Contract Energy (MWh)	Bid Price \$/MWh w/ Escalation	Escalation Rate Applied
2008			
2009			
2010			
2011			
2012			
2013			
2014			
2015			
2016			
2017			
2018			
2019			
2020			
2021			
2022			
2023			
2024			
2025			
2026			
2027			
2028			
2029			
2030			
2031			
2032			
2033			
2034			
2035			

\$ _____/MWh adder per additional \$100,000 of actual costs for construction of facilities between the Point of Interconnection and Grid Interconnection Point.

Wind Farms 50 MW and Under Only

Scenario D2 (2 MW Ramp Rate w/ On-Call Frequency Regulation and Exception to Ramp Down for Wind Drop-off events)

Option 1 – Fixed Price \$/MWh : _____

Option 2 – Pricing with Escalation			
Year	Annual Contract Energy (MWh)	Bid Price \$/MWh w/ Escalation	Escalation Rate Applied
2008			
2009			
2010			
2011			
2012			
2013			
2014			
2015			
2016			
2017			
2018			
2019			
2020			
2021			
2022			
2023			
2024			
2025			
2026			
2027			
2028			
2029			
2030			
2031			
2032			
2033			
2034			
2035			

\$ _____/MWh adder per additional \$100,000 of actual costs for construction of facilities between the Point of Interconnection and Grid Interconnection Point.

Wind Farms Between 50 MW and 100 MW

Scenario AA1 (Maximum Up/Down Ramp Rate of 2 MW/minute)

Option 1 – Fixed Price \$/MWh : _____

Option 2 – Pricing with Escalation			
Year	Annual Contract Energy (MWh)	Bid Price \$/MWh w/ Escalation	Escalation Rate Applied
2008			
2009			
2010			
2011			
2012			
2013			
2014			
2015			
2016			
2017			
2018			
2019			
2020			
2021			
2022			
2023			
2024			
2025			
2026			
2027			
2028			
2029			
2030			
2031			
2032			
2033			
2034			
2035			

\$ _____/MWh adder per additional \$100,000 of actual costs for construction of facilities between the Point of Interconnection and Grid Interconnection Point.

Wind Farms Between 50 MW and 100 MW

Scenario BB1 (2 MW Ramp Rate w/ On-Call Frequency Regulation)

Option 1 – Fixed Price \$/MWh : _____

Option 2 – Pricing with Escalation			
Year	Annual Contract Energy (MWh)	Bid Price \$/MWh w/ Escalation	Escalation Rate Applied
2008			
2009			
2010			
2011			
2012			
2013			
2014			
2015			
2016			
2017			
2018			
2019			
2020			
2021			
2022			
2023			
2024			
2025			
2026			
2027			
2028			
2029			
2030			
2031			
2032			
2033			
2034			
2035			

\$ _____/MWh adder per additional \$100,000 of actual costs for construction of facilities between the Point of Interconnection and Grid Interconnection Point.

Wind Farms Between 50 MW and 100 MW

Scenario CC1 (2 MW Ramp Rate w/ Exception to Ramp Down for Wind Drop-off events)

Option 1 – Fixed Price \$/MWh : _____

Option 2 – Pricing with Escalation			
Year	Annual Contract Energy (MWh)	Bid Price \$/MWh w/ Escalation	Escalation Rate Applied
2008			
2009			
2010			
2011			
2012			
2013			
2014			
2015			
2016			
2017			
2018			
2019			
2020			
2021			
2022			
2023			
2024			
2025			
2026			
2027			
2028			
2029			
2030			
2031			
2032			
2033			
2034			
2035			

\$ _____/MWh adder per additional \$100,000 of actual costs for construction of facilities between the Point of Interconnection and Grid Interconnection Point.

Wind Farms Between 50 MW and 100 MW

Scenario DD1 (2 MW Ramp Rate w/ On-Call Frequency Regulation and Exception to Ramp Down for Wind Drop-off events)

Option 1 – Fixed Price \$/MWh : _____

Option 2 – Pricing with Escalation			
Year	Annual Contract Energy (MWh)	Bid Price \$/MWh w/ Escalation	Escalation Rate Applied
2008			
2009			
2010			
2011			
2012			
2013			
2014			
2015			
2016			
2017			
2018			
2019			
2020			
2021			
2022			
2023			
2024			
2025			
2026			
2027			
2028			
2029			
2030			
2031			
2032			
2033			
2034			
2035			

\$ _____/MWh adder per additional \$100,000 of actual costs for construction of facilities between the Point of Interconnection and Grid Interconnection Point.

Wind Farms Between 50 MW and 100 MW

Scenario AA2 (Maximum Up/Down Ramp Rate of 3 MW/minute)

Option 1 – Fixed Price \$/MWh : _____

Option 2 – Pricing with Escalation			
Year	Annual Contract Energy (MWh)	Bid Price \$/MWh w/ Escalation	Escalation Rate Applied
2008			
2009			
2010			
2011			
2012			
2013			
2014			
2015			
2016			
2017			
2018			
2019			
2020			
2021			
2022			
2023			
2024			
2025			
2026			
2027			
2028			
2029			
2030			
2031			
2032			
2033			
2034			
2035			

\$ _____/MWh adder per additional \$100,000 of actual costs for construction of facilities between the Point of Interconnection and Grid Interconnection Point.

Wind Farms Between 50 MW and 100 MW

Scenario BB2 (3 MW Ramp Rate w/ On-Call Frequency Regulation)

Option 1 – Fixed Price \$/MWh : _____

Option 2 – Pricing with Escalation			
Year	Annual Contract Energy (MWh)	Bid Price \$/MWh w/ Escalation	Escalation Rate Applied
2008			
2009			
2010			
2011			
2012			
2013			
2014			
2015			
2016			
2017			
2018			
2019			
2020			
2021			
2022			
2023			
2024			
2025			
2026			
2027			
2028			
2029			
2030			
2031			
2032			
2033			
2034			
2035			

\$ _____/MWh adder per additional \$100,000 of actual costs for construction of facilities between the Point of Interconnection and Grid Interconnection Point.

Wind Farms Between 50 MW and 100 MW

Scenario CC2 (3 MW Ramp Rate w/ Exception to Ramp Down for Wind Drop-off events)

Option 1 – Fixed Price \$/MWh : _____

Option 2 – Pricing with Escalation			
Year	Annual Contract Energy (MWh)	Bid Price \$/MWh w/ Escalation	Escalation Rate Applied
2008			
2009			
2010			
2011			
2012			
2013			
2014			
2015			
2016			
2017			
2018			
2019			
2020			
2021			
2022			
2023			
2024			
2025			
2026			
2027			
2028			
2029			
2030			
2031			
2032			
2033			
2034			
2035			

\$ _____/MWh adder per additional \$100,000 of actual costs for construction of facilities between the Point of Interconnection and Grid Interconnection Point.

Wind Farms Between 50 MW and 100 MW

Scenario DD2 (3 MW Ramp Rate w/ On-Call Frequency Regulation and Exception to Ramp Down for Wind Drop-off events)

Option 1 – Fixed Price \$/MWh : _____

Option 2 – Pricing with Escalation			
Year	Annual Contract Energy (MWh)	Bid Price \$/MWh w/ Escalation	Escalation Rate Applied
2008			
2009			
2010			
2011			
2012			
2013			
2014			
2015			
2016			
2017			
2018			
2019			
2020			
2021			
2022			
2023			
2024			
2025			
2026			
2027			
2028			
2029			
2030			
2031			
2032			
2033			
2034			
2035			

\$ _____/MWh adder per additional \$100,000 of actual costs for construction of facilities between the Point of Interconnection and Grid Interconnection Point.

Non-Wind Farm Projects

Option 1 – Fixed Price \$/MWh: _____

Option 2 – Pricing with Escalation			
Year	Annual Contract Energy (MWh)	Bid Price \$/MWh w/ Escalation	Escalation Rate Applied
2008			
2009			
2010			
2011			
2012			
2013			
2014			
2015			
2016			
2017			
2018			
2019			
2020			
2021			
2022			
2023			
2024			
2025			
2026			
2027			
2028			
2029			
2030			
2031			
2032			
2033			
2034			
2035			

\$ _____/MWh adder per additional \$100,000 of actual costs for construction of facilities between the Point of Interconnection and Grid Interconnection Point.

Interconnection Cost Information

Bidders are requested to provide the following information:

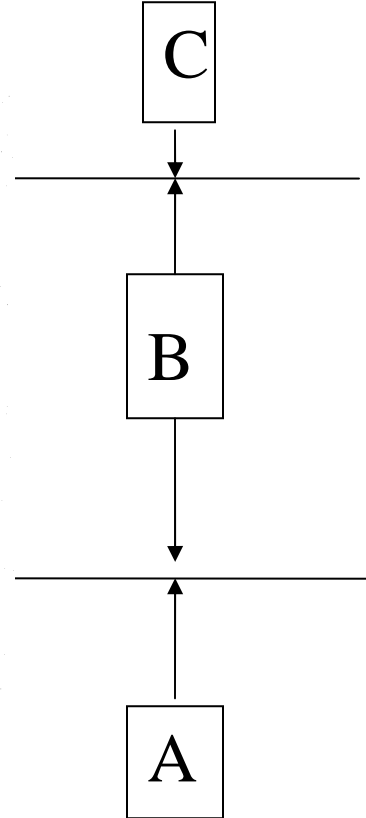
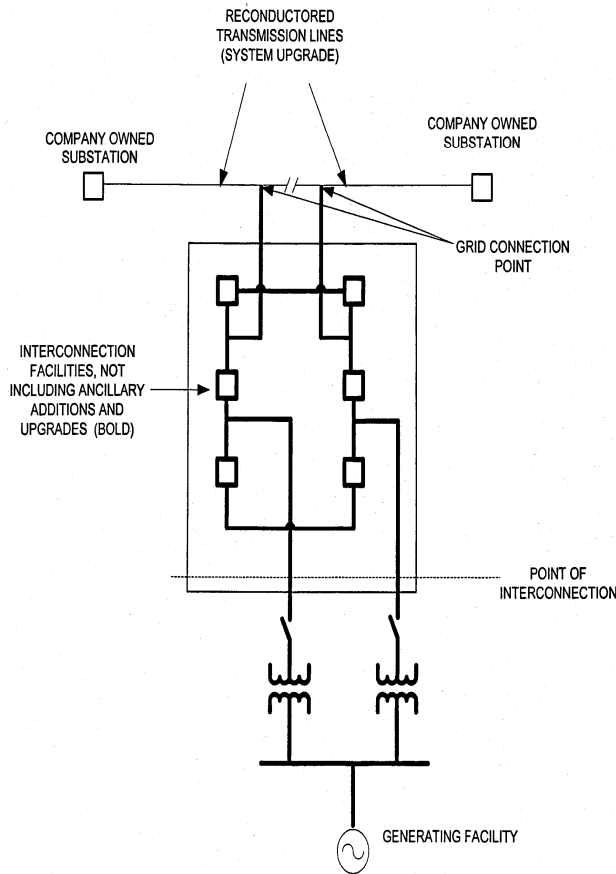

Section A – Facility to proposed Point of Interconnection. Bidders should include these costs in their pricing proposal. Please identify the Bidder's Proposed Point of Interconnection:_____.

Section B – Between proposed Point of Interconnection and Grid Interconnection Point. While HECO understands that these costs will ultimately be defined by an Interconnection Requirements Study, Bidders must include an estimated cost in this section and a pricing adjustment formula--\$/MWh for every additional \$100,000 of estimated interconnection-related capital costs-- that may be applied by HECO for adjusting their proposal price for each pricing scenario (see pricing tables in previous page) .

Section C – To be developed by HECO.

Interconnection Cost Estimate Sheet

Section A – Facility to proposed Point of Interconnection. Bidders should include these costs in their pricing proposal.

Bidder’s Proposed Point of Interconnection (location and description):

Section B – Provide bidder's cost estimate for facilities located between proposed Point of Interconnection and Grid Interconnection Point.

Capital Cost (\$):

Description (include Single Line Diagram as attachment):

5. Project Operational Requirements

Bidders should provide the following information requested regarding the project operational parameters. If information requested is not applicable to the specific technology, the Bidder should specify with an N/A.

5.1 Identify the Unit Capability (Assume Normal Operations)

	Net (MW) (to utility system)	Corresponding Gross (MW)
Minimum (normal operations)	_____	_____
Minimum + [25% x (Normal Top Load - Minimum)]	_____	_____
Minimum + [50% x (Normal Top Load - Minimum)]	_____	_____
Minimum + [75% x (Normal Top Load - Minimum)]	_____	_____
Normal Top Load	_____	_____
Emergency	_____	_____

5.2 Please list the Auxiliary Power Requirements for:

Start-up	_____
Normal Operations (from generator)	_____
Normal Operating Shutdown	_____
Forced Emergency Shutdown	_____
Maintenance Outage	_____

5.3 Identify the Expected Equivalent Availability Factor (NERC Definition)
(annual equivalent hours available/8760) _____%

5.4 Equivalent Forced Outage Rate (NERC Definition)

$$\frac{\text{(forced out hours + equivalent forced derated hours)}}{\text{(forced out hrs + svc hrs + equiv. forced derated hrs during reserve shutdown)}} = \text{_____}\%$$

5.5 Expected Performance for:

Undervoltage ride-through – Indicate the facility’s terminal voltage levels at the point of interconnection and elapsed time at which the facility will disconnect from the utility system, if any.

Underfrequency operation – Indicate the system frequency or frequencies at which the facility will disconnect from the utility system, if any.

Overvoltage ride-through – Indicate the facility’s terminal voltage levels at the point of interconnection and elapsed time at which the facility will disconnect from the utility system, if any.

Overfrequency operation – Indicate the system frequency or frequencies at which the facility will disconnect from the utility system, if any.

5.6 Maintenance Outage Requirements – Specify partial and complete outage requirements in weeks for the number of years required for the cycle to repeat (For example, list time interval of minor and major overhauls, and the duration of overhauls)

5.7 Specify all operating constraints

6. Energy Resource Plan

The Bidder is required to provide an energy resource or fuel supply plan for their project, which provides HECO with the necessary information to conduct an evaluation of the project's proposed generation profile consistent with the energy resource utilized by the Bidder. Bidders should therefore provide detailed information demonstrating that the operating performance and conditions proposed are supported by the availability of energy resources (i.e. wind, water, solar, etc.). Bidders should provide energy profiles, performance curves, or other relevant supporting documentation. The information requested is organized according to the type of project or energy resource. Bidders should respond only to relevant questions.

Wind energy projects:

- 6.1a Provide a summary of all collected wind data for the proposed site.
- 6.1b Indicate where the data was collected and its proximity to the proposed site. Include an identification of the location for the anemometers that were used to arrive at an assessment of the site generation capability.
- 6.1c Provide (a) at least one year of hourly wind resource data, or (b) a wind resource assessment report from a qualified meteorologist, or (c) both.
- 6.1d Provide a projection of gross and net annual energy production, including projections of monthly energy production, based on the wind resource data. Provide a projection of the expected hourly energy production by month for a one-year period.
- 6.1e Provide a site-adjusted power curve. Each curve should list the elevation, temperature and air density used.
- 6.1f Specify the assumptions for losses in the calculation of projected annual energy production.

Landfill gas

- 6.2a Provide a gas production forecast for each landfill based on the expected decay from the landfill. Provide a table that shows the annual, monthly and hourly projection of gas flow and energy export to the utility from each landfill. If a computer model is used to project gas production, please provide a copy of model output consistent with the required information noted above.
- 6.2b Provide supporting data that illustrates the expected generation from each landfill based on the projected gas production.

Biomass

- 6.3a Provide a resource assessment of available biomass fuel for the proposed project and its proximity from the project site.
- 6.3b Provide a plan for obtaining the biomass fuel, including a transportation plan.
- 6.3c Provide any contracts or letters of intent to acquire and transport the biomass fuel.
- 6.3d Demonstrate that projected energy output for the project is consistent with the energy supply available.
- 6.3e Provide expected amount of energy export to the utility by hour.

Hydro, solar and other renewable resources.

- 6.4a Provide an assessment of the available resource and the projected production profile for the project. Identify anticipated generation by hour and month for at least a one-year period and describe any trends in generation capability over time. Also describe the methodology and in-house or consulting expertise used to arrive at the generation estimates.
- 6.4b In the case of hydro, describe the project characteristics in terms of water flow (on a monthly basis) and head, and state the assumptions regarding seasonal variations, and a conversion of such flow into kilowatts and kilowatt-hours. Provide monthly flow duration curves based upon daily stream flow records.
- 6.4c Identify if the project is run-of-river or has storage capability.

Other

- 6.5 If a Bidder expects to produce any product in addition to the electrical output to be sold to HECO, please identify the product and the expected annual level of output.
- 6.6 Identification of availability of fuel supply (if applicable).
- What is the availability of the fuel supply?
 - Are there commitments from fuel suppliers? If so, please provide a copy with confidential information redacted if necessary.

7. Financial/Legal

Bidders are required to provide responses to all questions below. Bidders are required to demonstrate the financial viability of their project. Bidders should provide the following information:

- 7.1 Identification of equity participants.
 - Who are the equity participants in the project?
- 7.2 Evidence that the project will be financed.
 - How will the project be financed?
 - Is there a written commitment from the equity participants? If so, please provide a copy with confidential information redacted if necessary.
 - Discuss and/or provide supporting information on any project financing guarantees.
 - Does the developer envision any conditions precedent to project financing other than execution of the power purchase agreement and Hawaii Public Utilities Commission approval of the power purchase agreement? If so, what do you expect them to be?
- 7.3 Description of the Bidder's organizational structure from a financial and legal perspective, including any general and limited partners, involvement of subsidiaries, and providers of capital.
- 7.4 Provide a description of the financing plan for the project, including construction and term financing. The financing plan should address information contained in the pro forma, such as:
 - The project's projected financial structure;
 - Expected sources of debt and equity financing;
 - Estimated capital cost.
 - Evidence the project is financeable

In addition, the financing plan should address the financing of development costs. All bidders are required to provide this information.

- 7.5 Provide documentation illustrating the experience of the project sponsor in securing financing for projects of similar size and technology. For each project provide the following information:
 - Project name and location
 - Project type and size
 - Date of construction and permanent financing
- 7.6 Provide evidence that the Bidder has the financial resources and financial strength to complete and operate the project as planned.

- 7.7 Provide copies of the most recent audited financial statement or annual report for each Bidder, including affiliates of the Bidder. Also, list the current credit rating from Standard & Poor's and Moody's for the sponsor, affiliates, partners, and credit support provider.
- 7.8 The Bidder should demonstrate its ability (and/or the ability of its credit support provider) to provide the required security, including its plan for doing so (including type of security, sources of security and a description of its credit support provider).
- 7.9 Provide a description of any current credit issues regarding the Bidder or affiliate entities raised by rating agencies, banks, or accounting firms.
- 7.10 Describe the implication of the federal Production Tax Credits or Investment Tax Credits (or similar incentives) on the viability of the project.
- 7.11 Provide a memorandum with supporting information demonstrating that the proposal will not be subject to Variable Interest Entity treatment and that HECO will not have to carry this entity on its financial statements.
- 7.12 Pro forma income and cash flow statement conforming to Generally Accepted Accounting Principles for the project for the term of the proposed Power Purchase Agreement (include revenue and cost data by major categories, debt service, depreciation expenses and other relevant information). Bidders should note that this information will be required of short-listed bidders only and will be requested by HECO upon short-list notification.
- 7.13 Bidders must disclose any litigation related to projects owned or managed by them or any of their affiliates in the United States.

8. Siting

This section of the response package addresses siting and right-of-way issues. Bidders should ensure that the threshold criteria for siting are verified in their responses.

8.1 Provide a TMK map of the site that clearly identifies the location of the site, the total acreage, the interconnection point, and the relationship of the site to other local infrastructure. In addition to providing the required map, provide a site layout plan which illustrates the location of all equipment and facilities on the site.

8.2 Evidence of right to use site.

- Does the project have a right to use the site (e.g., by virtue of ownership or land rights obtained from the owner)?
- Does the project need any entitlements to use the site?
- Include any relevant documentation, e.g. letter of intent to negotiate a lease or purchase of site, or evidence of actual lease or purchase of site.
- If the project does not have site control, provide a timeline when it is anticipated that the project will receive entitlements to use the site, obtain a lease to, or purchase the site. For reference, use the execution date of the power purchase agreement as the starting point.

8.3 Provide evidence that the site is properly zoned. If the site is not currently zoned properly, identify present and required zoning and/or land use designations and provide a permitting plan and timeline to secure the necessary approvals.

8.4 Identify any rights-of-way or easements that are required for access to the project or for interconnection. Describe the status of rights-of-way and easement acquisition, and describe the plan for securing the necessary rights-of-way, including the proposed timeline.

8.5 Describe whether the project has the capability for expansion at the proposed site. If so, describe the expansion capability possible.

9. Environmental Permits

This section addresses environmental issues associated with project siting and operations. The Bidder should identify environmental impacts associated with the proposed project and its plan to mitigate such impacts. Included in this section are technical environmental issues associated with air, water, solid waste, land use, noise, and other environmental issues. This section also addresses specific environmental permitting considerations,

9.1 Identify all permits, licenses, and environmental assessments and/or environmental impact statements required.

- Provide a list of all Federal and Hawaii permits, licenses, and environmental assessments and/or environmental impact statements required to construct and operate the project.

Identify governmental agencies for issuing permits and licenses.

- Identify the governmental agencies which will issue or approve the required permits, licenses, and environmental assessments and/or environmental impact statements.

Prepare timeline to complete acquisition of permits, licenses, and environmental assessments and/or environmental impact statements.

- Provide the anticipated timeline for seeking and receiving the required permits, licenses, and environmental assessments and/or environmental impact statements, using the execution date of the power purchase agreement as the starting point. Please include a narrative on the basis for the assumed timeline.

9.2 Provide a preliminary environmental assessment of the site. The analysis should address each of the major environmental areas and sub-areas as presented below:

- Site development
- Air quality
- Water resources
- Ecology
- Land use
- Cultural resources
- Previous site use
- Noise level
- Aesthetic/visual

9.3 Identify the location of the nearest residence and the nature of any buildings within 500 feet of the site.

9.4 Provide documentation identifying any potential environmental impediments to project development and the plan to mitigate the impediment

- 9.5 Identify a community support and a communications plan to gain support for or acceptance of the proposed project. Identify support for and/or acceptance of the proposed project by the affected communities and the general public.
- Identify communities and other stakeholders that may be affected by the proposed project. How will they be affected?
 - How will affected communities and the general public be informed about the proposed project?
 - Will the affected communities and the general public be given an opportunity to provide the developer with feedback and comments on the proposed project? What will the developer do with the feedback and comments received?

10. Engineering and Technology

This section includes questions pertinent to the engineering design and project technology. Bidders should provide information about the specific technology or equipment including the track record of the technology and equipment.

- 10.1 Provide a reasonable but preliminary engineering plan which includes the following information:
- Name of principal engineering firm responsible for facility design
 - Type of generation technology
 - Major equipment to be used
 - Equipment vendors selected/considered
 - History of equipment operations
 - Equipment procurement strategy
- 10.2 Provide name of key equipment suppliers and information that illustrates and discusses the proposed equipment and technology, lead times for delivery to Hawaii, and suppliers prior experience with equipment operation in tropical island environments.
- 10.3 Please identify similar equipment by the same manufacturer that are presently in commercial operations including the number installed, installed capacity and estimated generation.
- 10.4 Provide evidence that the technology to be employed for energy production is ready for transfer to the design and construction phases.
- Describe the technology to be employed for energy production.
 - To the developer's best knowledge, are there, or have there been any similar plants in commercial operation? If not, i) are there, or have there been, any pilot projects, and ii) please provide evidence that the technology to be employed for energy production has been proven. Such evidence may include copies of studies confirming technical feasibility.
- 10.5 Please indicate if the Bidder has secured its equipment (e.g. wind turbines) for the project. If not, identify the long-lead equipment options and describe the timing for securing equipment.

11. Operation and Maintenance

Operations and maintenance is viewed as an important element of successful project operations by HECO. HECO is interested in projects that can demonstrate that the maintenance plan, level of funding, and mechanism for funding will ensure reliable operations during the term of the contract.

- 11.1 Provide an operation and maintenance plan for the project that demonstrates the long term operational viability of the proposed project. The plan should include a discussion of the staffing levels proposed for the project, the expected role of the project sponsor or outside contractor, scheduling of major maintenance activity, maintenance funding levels, and the plan for testing equipment.
- 11.2 Indicate whether or not the project sponsor is willing to coordinate the maintenance schedule for the project with the annual maintenance schedule of HECO.
- 11.3 Describe the status of the project sponsor in securing any operation and maintenance agreements or contracts. Include a discussion of the sponsors plan for securing a long-term O&M contract.
- 11.4 Provide examples of the Bidder's experience with O&M services for other similar projects.

12. Project Schedule

Bidders are required to provide a complete critical path schedule for the project from the notice of selection of the project for contract negotiation to the start of commercial operations. For each project element, list the start and end date.

Bidders should ensure that the schedule provided in this section is not inconsistent with the milestone events contained in the form PPA.

- 12.1 Identify the elements on the critical path. The schedule should include, as a minimum, facility contracts, construction, siting, environmental permitting (anticipated submittal and approval), fuel supply, financing, engineering, procurement, local permits and any other requirements that could influence the project schedule, and the Commercial Operation Date. The project schedule should include dates for all construction and applicable reporting milestone events specified in the model PPA.

13. Project Management/Experience

Bidders are required to demonstrate project experience and management capability to successfully develop and operate the project proposed. HECO is interested in a project team which has demonstrated success in projects of similar type, size and technology and can demonstrate an ability to effectively work together to bring the project to commercial operation in a timely fashion.

- 13.1 Provide an organizational chart for the project that lists the project participants and identifies the management structure and responsibilities.
- 13.2 For each of the project participants (including the Bidder, partners, and proposed contractors), provide statements that list the specific experience of the firm in developing, financing, owning, and operating generating facilities, other projects of similar type, size and technology, and any evidence that the project participants have worked jointly on other projects.
- 13.3 Provide a management chart which lists the key personnel dedicated to this project and provide biographies of the key personnel.
- 13.4 Provide a listing of all projects the project sponsor has successfully developed or that are currently under construction. Provide the following information as part of the response:
 - Name of the project
 - Location of the project
 - Project type, size and technology
 - Commercial operation date
 - Capacity factor of the unit for the past three years
 - Availability factor of the unit for the past three years
 - References, including the names and current addresses and telephone numbers of individuals to contact for each reference.
- 13.5 With regard to the Seller's project team, identify and describe the entity responsible for the following:
 - Construction Period Lender
 - Operating Period Lender
 - Financial Advisor
 - Environmental Consultant
 - Owner's Engineer
 - Construction Contractor
 - Transmission Consultant
 - Legal Counsel

15. Required Interconnection Technical Information

15.1 Provide Single-Line Diagram(s) for the generation and interconnection facilities:

- a. The Single-line diagram(s) should include:
 - i. Transformers:

For main and generator step up transformer(s), show:

 - Transformer voltage and MVA ratings.
 - Transformer impedance(s).
 - Transformer winding connections and grounding. If neutrals are grounded through impedance, show the impedance value.
 - ii. Breakers:

For the Breakers include:

 - The voltage, continuous current and interrupting capability ratings.
 - The trip speed (time to open)
 - iii. The protective relaying and metering for the generators, buses, and all other main substation equipment.
 - iv. For the potential transformers, indicate the type, quantity, ratio, and accuracy rating.
 - v. For the current transformers, indicate the type, quantity, ratio, and accuracy rating, and thermal rating factor.
 - vi. Auxiliary power devices (e.g. capacitors, reactors, storage systems, etc.) and their rating(s); additional inquiries may be made to obtain technical data for these devices.
 - vii. The generator(s) voltage, impedances, and MVA ratings.
 - viii. The generator grounding method. If the generator is not solidly grounded, provide the grounding method details and equipment ratings.

15.2 Provide a plan map of the facilities; indicate the interconnection point to the HECO system.

15.3 Provide the technical specifications and other information available for the generators included in the proposal.

16. Alternatives

With reference to Section 2.6, Bidders should describe any alternative options to their proposal which could include a different pricing formula, proposal size, in-service date, or higher security levels, if applicable.

17. Red-lined Version of Power Purchase Agreement

Please attach red-lined version of model PPA.