



HAWAII ELECTRIC LIGHT COMPANY, INC.

**ELECTRICAL PLAN REQUIREMENTS
FOR COMMERCIAL SERVICE**

SEPTEMBER 27, 2008

Revised September 27, 2008

SEPTEMBER 19, 2007

NOTICE

TO: APPLICANTS FOR COMMERCIAL ELECTRICAL SERVICE

SUBJECT: ELECTRICAL PLAN REQUIREMENTS FOR COMMERCIAL SERVICE

1. In order to process requests for commercial electrical service as quickly as possible, HELCO requires customers to submit electrical plans.

HELCO's tariff, Electric Service Installation Manual (ESIM) and Meter Standards and Policies are issued to consultants, contractors, and customers who apply for service from HELCO. The electrical plans submitted must conform to HELCO's tariff, ESIM, Electric Utility Service Equipment Requirement (EUSERC), Hawaii Ordinances, the 2002 Edition of the National Electric Safety Code (NEC), (and the National Electric Code (NEC)).

2. THE ELECTRICAL PACKAGE MUST INCLUDE THE FOLLOWING FIVE ITEMS:

One Line Diagram

Specify the service voltage, point of delivery, service entrance conductors, meter socket class, terminals, electric rate schedule, and grounding. A self-contained meter socket requires test bypass facilities. Instrument meter sockets require a test switch.

Meter Elevation

Show the meter's elevation by indicating the height of the meter's center line above the finished grade (see part 3 for meter height requirements). Minimum clearances between the meter and the building are 7 inches from top, 6 inches from side and 4 feet in front of the meter base.

Panel Schedule(s)

Furnish panel schedules with individual loads in KVA, connected KVA (KVAC), and demand KVA (KVAD).

Location Plan

Prepare a location plan showing the meter on the structure relative to the roadway. Include the tax map key (TMK).

Service Data

Please provide the following information:

1. Service voltage, connected KVA and demand KVA, service entrance conductor sizes.
2. Electric rate schedule for the new metered load.
3. Type of service (overhead or underground).
4. Billing address.
5. Nameplate load rating for welding equipment, electric motors over 50 horsepower and other large electrical equipment that will be operated as part of the new load (needed to limit voltage disturbances to nearby customers).

3. HOW HELCO WILL USE THE ELECTRICAL PLAN INFORMATION

Overall Purpose

The overall purpose of checking the plans is to safeguard people and property from hazards arising from the use of electricity.

Verification of HELCO Meter Standards

Information on the demand current determines the type of meter needed. Self-contained meters are required for demand current less than 150 amperes.

Verification on Electric Rate Schedule and Meter Height

Rate Schedules:

Schedule "G" – Applicable to general lighting and/or power loads less than or equal to 5,000 kilowatt hours per month, and less than or equal to 25 kilowatts and supplied through a single meter.

Schedule "J" – Applicable to general lighting and/or power loads which exceed 5,000 kilowatt hours per month, or 25 kilowatts three times within a twelve month period and supplied through a single meter.

Schedule "H" – Applicable only to commercial cooking and heating service including heat pump water heaters. This schedule applies only where the voltage supplied by the Company is less than 600 volts.

Schedule "P" – Applicable to large light and/or power service supplied and metered at a single voltage and delivery point.

Meter Mounting Height:

Outdoors – 5 to 6 ft for all meters.

Project Assignment

The commercial service request is assigned to a project planner based on the KVA requirements and the tax map key. Projects are grouped as follows: 0-10 KVA, 11-75 KVA, 76-500 KVA, and 501 KVA and greater loads.

Project Location

The tax map key identifies the location of the project on the HELCO system. Information on the meter location verifies whether it is an outdoor/indoor meter and whether the meter is in an approved location.

Service Requirements

Information on demand KVA and service voltages help to determine the size of service conductors and transformers. If a customer is adding new load to its existing electrical service, larger transformers and wires may be needed. HELCO will determine whether this service upgrade is necessary.

If you have any questions on these guidelines, please call our Engineering Department at 935-1171.

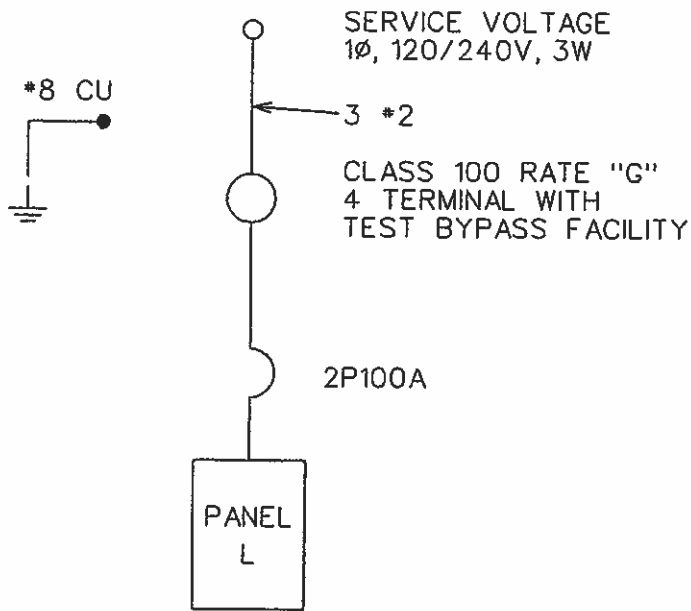

ONE LINE DIAGRAM

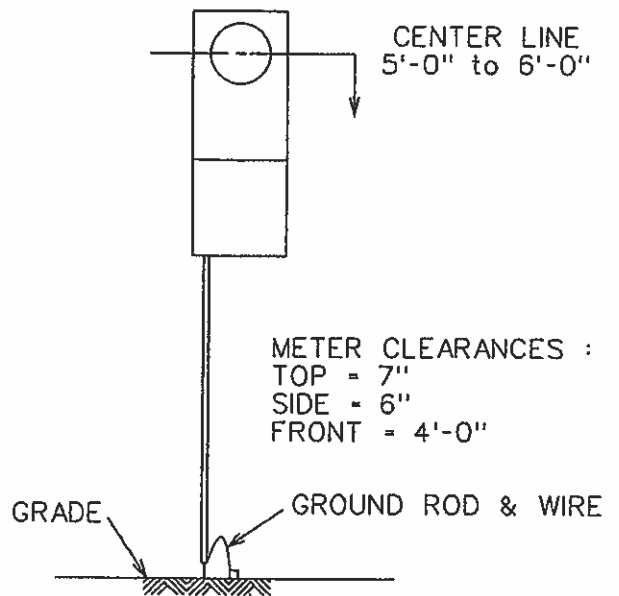

METER ELEVATION

PANEL SCHEDULE

PANEL L 120/240, 1 PHASE, 3 WIRE, 10,000 AIC					
CKT.	DESCRIPTION	AØ	BØ	BKR	WIRE
1	LIGHT	1.2		1P20	12
2	RECEPTACLE		1.2	1P20	12
3	WATER HEATER	2.2		2P30	10
4	WATER HEATER		2.2		10
5	AIR CONDITIONER	1.5		2P20	12
6	AIR CONDITIONER		1.5		12
CONNECTED KVA		9.8			
DEMAND FACTOR		0.7			
DEMAND KVA		7.0			

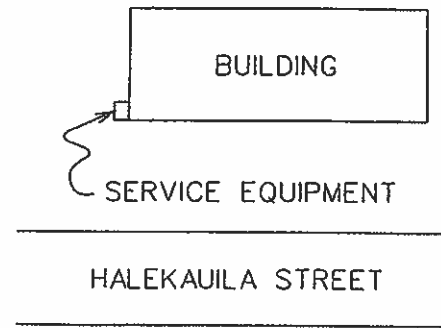

LOCATION PLAN

SERVICE DATA

- 1Ø, 120/240V, 3W
- LOAD DATA :

METER	CONNECTED KVA	DEMAND KVA
1	9.8	7.0
- SERVICE ENTRANCE CONDUCTORS : 3*2CU
- METERING : METER STANDARD B-5: RATE "G"
- TYPE : OVERHEAD
- BILLING ADDRESS : JOHN DOE
P.O. BOX 1027
HILO, HI 96720

HAWAII ELECTRIC LIGHT CO., INC. HILO, HAWAII			
ELECTRICAL PLAN REQUIREMENTS COMMERCIAL SERVICE			
EST./REQ. NO.		DESIGNED/DRAWN DM/VV	
CHK'D/APP'D		SCALE N.T.S.	
W.O. NO.	JP. NO.	DATE	2-2-94
T.M.X.		NUMBER	